

**Universal Service Fund**

(A company listed under Section 42 of the Companies Ordinance 1984)

*“Every Pakistani has the right to modern telecommunication services and we strive to provide that.”*

**REGISTRATION FORM FOR USF PROJECT # \_\_\_\_\_**

Name of Applicant: \_\_\_\_\_

Registered Address: \_\_\_\_\_

Postal Address: \_\_\_\_\_

Phone: \_\_\_\_\_

Fax: \_\_\_\_\_

Email: \_\_\_\_\_

Contact Person for correspondence: \_\_\_\_\_

Person authorized for Registration:  
(attach copy of authorization) \_\_\_\_\_

Nature of applicant’s License (copy attached): \_\_\_\_\_

Telecom services authorized under the License: \_\_\_\_\_

Date of Expiry of License: \_\_\_\_\_

Licensed territory: \_\_\_\_\_

Audited/Unaudited Report of USF Contributions as payable & paid todate:  
(summarize and attach copy of full report) \_\_\_\_\_

\_\_\_\_\_

\_\_\_\_\_

Amount of any USF contributions outstanding to-date: \_\_\_\_\_

Proof of payment: \_\_\_\_\_

List of Consortium members, if registration is for consortium:

\_\_\_\_\_

\_\_\_\_\_

\_\_\_\_\_

Applicant declared eligible by PTA:  Yes  No  
(Attach copy of eligibility letter from PTA)

Pay Order/DD of PKR 25,000 registration fee attached:  Yes  No

**Certificate:**

Certified that the information set out above is correct to the best of my information and belief, and nothing material has been concealed therefrom.

\_\_\_\_\_  
(Signature of Authorized Representative)

NIC: \_\_\_\_\_

Date: \_\_\_\_\_



## **Universal Service Fund**

(A company setup under Section 42 of the Companies Ordinance 1984)

---

---

**REQUEST FOR APPLICATIONS**  
**TO PROVIDE**  
**UNIVERSAL SERVICE FUND TELECOMMUNICATIONS SERVICES**  
**Khyber Pakhtunkhwa Package**

**Project ID: USF/SP/OpticFiber/2013/Khyber-Pakhtunkhwa**

**Issued at Islamabad**

**19<sup>th</sup> April 2013**

<b>USFCo Fifth Floor, HBL Tower, Jinnah Avenue, Islamabad Pakistan</b>	<b>Tel: 051-9212308 &amp; 9212309 Fax: 051-9214261</b>
--	--

**USFCo**  
 Request for Applications to provide  
 Universal Service Fund Telecommunications Services

**Table of Contents**

**Part I Introduction.....1**

1. Purpose of the RFA Process ..... 1

2. Source of Funds ..... 1

3. Current Legal, Regulatory, and Market Regime..... 2

4. USF Policy ..... 3

5. USF Coverage Requirements..... 3

6. USF Service Requirements ..... 4

7. USF Contributors and Eligibility ..... 4

8. Tentative Time Schedule ..... 5

9. Project Administration and Correspondence ..... 5

**Part II Rights and Obligations of USF Service Provider .....6**

10. Exclusivity ..... 6

11. Roll-out of USF Optic Fiber Network and Supply of USF OFC Services ..... 6

12. USF Subsidy Payments..... 6

13. Service Availability and Quality Specifications ..... 6

14. Scope of Service ..... 7

15. Regulation of Operators ..... 7

16. Interconnection and Facilities Sharing..... 7

17. (Not Applicable) ..... 8

18. Type Approval ..... 8

19. Regulation of USF Service Charges ..... 8

20. Authority to Construct and Use Facilities..... 8

21. Requirement to Procure and Manage the USF Network ..... 9

22. Transfer or Change of Control..... 9

23. Access to Public and Private Lands ..... 9

24. Force Majeure ..... 9

25. Dispute Resolution..... 9

26. Technical Auditor ..... 9

27. Compliance with Law ..... 10

28. Term of USF Services and Subsidy Agreement ..... 10

29. Other Obligations under USF Services and Subsidy Agreement ..... 10

30. Fees Payable by the USF Service Provider..... 10

31. (Not Applicable) ..... 10

**Part III Instructions to Applicants.....11**

32. Selection of Successful Applicant ..... 11

33.	Pre-proposal Meeting.....	11
34.	Qualification Criteria .....	12
35.	Financing Capacity .....	12
36.	Operational Experience.....	12
37.	Applicant Eligibility.....	13
38.	Consortium Applicant.....	14
39.	Bid Bond .....	14
40.	Responsiveness of Proposals .....	15
41.	Content and Format of Proposals.....	15
42.	Part 1 Structure Requirements – Qualifications and Service Proposal.....	16
43.	Part 2 Subsidy Proposal .....	22
44.	Compliance Checklist .....	23
45.	Submission of the Proposal.....	24
46.	Delivery of the Proposal .....	25
47.	Opening of Proposals.....	25
48.	Selection Process and Evaluation of Proposals .....	26
49.	Fraud or Corruption .....	27
50.	Period of Validity of Proposal .....	29
51.	Grounds for Rejection of Proposal .....	29
52.	Subsequent Disqualification and Ineligibility.....	29
53.	Letter of Intent .....	30
54.	Performance Bond .....	31
55.	Information Provided by USFCo.....	31
56.	Communications, Comments and Requests for Clarification.....	31
57.	Confidentiality of Proposals .....	32
58.	USFCo Use of Proposals .....	33
59.	Cost of Proposal and Bidding .....	33
60.	Reservation of Rights.....	33
61.	Legal and Formal Requirements.....	33
	<b>Part IV Definitions.....</b>	<b>35</b>
62.	Definitions.....	35

## **Annexes**

- Annex 1** USF Subsidy Proposal Form
- Annex 2** Bid Bond Form
- Annex 3** World Bank Eligibility Guidelines<sup>1</sup>
- Annex 4** Form of Letter Regarding Compliance with Licence(s)
- Annex 5** Compliance Checklist
- Annex 6** Draft of Proposed USF Services and Subsidy Agreement
- Annex 7** Dispute Resolution Terms
- Annex 8** Tentative Time Schedule & Correspondence Contact

---

<sup>1</sup> Only applicable if Project is financed by World Bank.

## Part I Introduction

### 1. Purpose of the RFA Process

- 1.1 All telecommunications licences issued by the Pakistan Telecommunications Authority (“PTA”) subsequent to the *De-Regulation Policy 2003* and the *Mobile Cellular Policy 2004* provide for contribution by licensees to a Universal Service Fund (“USF”).
- 1.2 The purpose of this Request for Applications (“RFA”) is to invite holders of such licences (“USF Contributors”) to submit Proposals, either individually or as part of a consortium, for providing USF Optic Fiber Network connectivity to all unserved Tehsil Headquarters for provision of USF OFC Services in defined regional areas (“USF Areas”) in Pakistan pursuant to a 10 year USF Services and Subsidy Agreement.
- 1.3 This RFA is part of a universal service program initiated by the Government of Pakistan (“GoP”), which is aimed at increasing access to telecommunications networks and services in un-served and under-served areas of Pakistan in a manner consistent with fair competition, international best practices, and existing sector policies and GoP commitments.
- 1.4 GoP has created a not-for-profit federal Government owned and controlled Universal Service Fund company (“USFCo”) to administer the USF, including the process initiated by this RFA (“RFA Process”). It is GoP’s intent that USFCo apply part of the USF toward payment of a one-time subsidy (the “USF Subsidy”) to be paid pursuant to the USF Services and Subsidy Agreement to assist in meeting the costs of constructing the USF Optic Optic Fiber Network in the USF Areas.
- 1.5 Further information on the proposed USF OFC Services, USF Optic Fiber Network and USF Areas is set out in this RFA.
- 1.6 It is the intention of GoP to act quickly to implement its policy of extending access to telecommunications networks and services in un-served and under-served areas in Pakistan.

### 2. Source of Funds

- 2.1 Pursuant to Section 33A of the Act, the sources of funding USF shall consist of
  - (a) grants made by the Federal Government and the Provincial Governments;
  - (b) prescribed contribution by licensees;

- (c) sale proceeds from the auction of the right to use radio spectrum;
  - (d) loans obtained from the Federal Government; and
  - (e) grants and endowments received from other agencies.
- 2.2 Not Applicable.
- 2.3 Not Applicable.

### 3. **Current Legal, Regulatory, and Market Regime**

- 3.1 Before 1996, Pakistan's telecommunications markets were governed by the *Telegraph Act, 1885* and *Wireless Telegraphy Act, 1993*. Most telecommunications services were provided by the GoP's Telegraph and Telephone Department. That Department was converted into a statutory corporation in 1990 as the Pakistan Telecommunication Corporation ("PTC") and later in 1996 it was converted into a public limited company Pakistan Telecommunication Company Limited ("PTCL"). Competitive mobile telephone service was launched in 1991. Payphone service was launched in 1993. But of these competitors, only PTC and then PTCL had a formal duty to serve cities, towns, villages and Muzas in all areas of Pakistan.
- 3.2 Additional mobile, Wireless Local Loop (WLL), fixed-line Local Loop ("LL") and Long Distance International ("LDI") licensing since 2004 has increased competition substantially. Use of telecommunications services has expanded rapidly in this increasingly competitive environment. More than twenty-six providers offer voice telephony services in Pakistan. Mobile subscriber ship has grown from 70,000 in 1996 to about 120 million by May 2012. WLL subscriber ship increased to nearly 3.1 million by March 2012. Combined teledensity rose from 2.3 per 100 in 2002 to 72.1% by 2012, with mobile service penetration reaching 68.6%.
- 3.3 The *Mobile Cellular Policy (2004)* and *Pakistan Telecommunications (Re-organisation) (Amendment) Act, 2006* require that PTCL and all mobile licensees provide significant geographic coverage. Yet, in rural areas, teledensity remains very low. Making telecommunications services available country-wide is a GoP priority.
- 3.4 In a competitive sector, it is not appropriate to impose universal service obligations on a single operator. Accordingly, the *De-Regulation Policy (2003)* at section 5, the *Mobile Cellular Policy (2004)* at section 8, and the *Pakistan Telecommunications (Re-organisation) Act, 1996* at section 33A require that PTCL and all subsequent fixed and mobile licensees pay into the USF.



- 3.5 Persons who enter into a USF Services and Subsidy Agreement as a result of the RFA Process (“USF Service Providers”) will receive a subsidy payment from the USF to extend USF OFN connectivity to unserved Tehsil HQs to provide USF Optic Fiber Services to these defined areas, thus facilitating increase in rural teledensity. The amount of the USF subsidy payment will be established in accordance sections 12 and 43 of this RFA. The subsidy payment will be made in one or more instalments, against identified Project Implementation Milestones, in accordance with the USF Services and Subsidy Agreement.

#### 4. **USF Policy**

- 4.1 The *Universal Service Fund Policy* (“USF Policy”) is the policy framework guiding the RFA Process. It sets out goals, objectives, and guidelines for using USF funding to meet certain basic telecommunication and ICT services needs in areas of Pakistan which would otherwise remain unserved.
- 4.2 The USF Policy’s goals include making voice telephony and Internet access data services available and affordable to progressively greater proportions of Pakistan’s rural population.
- 4.3 The USF Policy’s objectives for 2010 include 85% coverage of the country’s population (and therefore access to service if desired), and a preference for one telecentre per 5,000 people, with a minimum target of one telecentre per 10,000 people in USF Areas. This RFA and similar USFCo initiatives are intended to meet these objectives by introducing service in defined USF Areas.
- 4.4 The USF Policy will guide the actions of USFCo in administering the Universal Service Fund. That administration includes the use of the USF Services and Subsidy Agreement, with compliance monitoring and penalties for non-performance, including forfeiture of bank guarantees. Technological features of the USF Policy include technological neutrality, an emphasis on shared access points, and mandated infrastructure sharing to facilitate multiple operators in the same area. Economic features include capping USF service prices at nationally available retail prices, and a “negative auction” RFA Process to use bidding competition among licensees to minimize the amount of any particular USF Subsidy, and to maximize overall benefits from the fund. Together, these features establish a USF regime to extend telecommunications services to rural locations in a sustainable manner consistent with fair competition.

#### 5. **USF Coverage Requirements**

The geographic locations that are the subject of this RFA and related USF Subsidy (the “USF Areas”) are identified in detail in Schedule C of the USF Services and Subsidy Agreement enclosed as Annex 6. Applicants must demonstrate that the USF Optic Fiber

Networks they propose provide USF OFC services to all of the un-served Tehsil Headquarters and towns identified in Schedule C of the USF Services and Subsidy Agreement as being mandatory for USF Optic Fiber Network and USF OFC Services.

## 6. **USF Service Requirements**

The Traffic Matrix (Bandwidth Capacities) for each Optic Fiber Link included in this Package to be provided by the successful Applicant selected pursuant to this RFA are identified in Schedules A and B of the USF Services and Subsidy Agreement enclosed as Annex 6.

## 7. **USF Contributors and Eligibility**

- 7.1 Persons whose Local Loop (“LL”) Wireless Local Loop (“WLL”), Long Distance and International (“LDI”) or Telecommunication Infrastructure Provider (“TIP”) Licence was issued after adoption of the *Deregulation Policy (2003)*, and persons whose mobile cellular licence was issued or renewed after adoption of the *Mobile Cellular Policy (2004)*, (collectively, “USF Contributors”) have an obligation to contribute 1.5% of annual gross revenues to the Universal Service Fund, less inter-operator fees and related payments mandated by the PTA or Frequency Allocation Board (“FAB”).
- 7.2 Any other licensee who has had its licence issued, re-issued or amended to include Universal Service Fund contribution payment requirements will, on satisfaction of those requirements, be recognized as a USF Contributor as well.
- 7.3 Eligibility to participate in the RFA process is limited to USF Contributors under the Universal Service Fund Rules, 2006 (the “Rules”)<sup>2</sup>.
- 7.4 Rule 24(12) sets out the following further restriction:

*No single licensee may accumulate more than fifty per-cent of the total amount of USF subsidies awarded by the USF Company in multiple auctions. The period during which a licensee’s accumulation and proportion of USF subsidy amounts will be defined in guidelines or statements of auction procedures to be issued by the USF Company from time to time.*

USFCo has developed guidelines under Rule 24(12) which are available at USF website [www.usf.org.pk](http://www.usf.org.pk). Applicants should consider the potential application of this restriction in considering their bidding strategy, particularly where multiple Packages are being offered.

---

<sup>2</sup> See Rule 24(12) of the USF Rules 2006, as amended.

8. **Tentative Time Schedule**

- 8.1 The tentative timetable for the RFA events, beginning with publication of the pre-auction notice, is set out in Annex 8 of RFA.

9. **Project Administration and Correspondence**

- 9.1 Nominated Contact for all correspondence relating to this RFA is provided in Annex 8 of this RFA:

**End of Part I**

## **Part II**

### **Rights and Obligations of USF Service Provider**

10. **Exclusivity**

A USF Service Provider will not have any exclusive rights to provide USF OFC Services in the USF Areas.

11. **Roll-out of USF Optic Fiber Network and Supply of USF OFC Services**

The USF Optic Fiber Network shall be constructed and otherwise rolled out in accordance with the Project Implementation Milestones, providing USF OFC services to all Tehsils HQs or Towns identified in Schedule C of the USF Services and Subsidy Agreement as being mandatory for USF Optic Fiber Network and USF OFC Service coverage. Once the USF Optic Fiber Network has been rolled out, the USF OFC Services shall be supplied by the USF Service Provider in accordance with the USF Services and Subsidy Agreement.

12. **USF Subsidy Payments**

In order to promote GoP's policy of expanding telecommunications services and access in un-served areas, a USF Subsidy shall be paid to the USF Service Provider to help meet the capital costs of rolling out the USF Network. The USF Subsidy payments shall be made in accordance with the USF Services and Subsidy Agreement enclosed as Annex 6.

13. **Service Availability and Quality Specifications**

- 13.1 Applicants must demonstrate that the USF Optic Fiber Networks they propose will provide USF OFC services to all of the Tehsils Headquarters or towns identified in Schedule C of the USF Services and Subsidy Agreement as being mandatory for USF Optic Fiber Network and USF OFC Services.
- 13.2 The USF Service Provider must roll-out and operate the USF Optic Fiber Network substantially in accordance with the plans submitted and the technology described in its accepted Proposal.
- 13.3 The USF Service Provider must also roll-out and operate the USF Optic Fiber Network so that the USF OFC Services meet all applicable quality of service measures and requirements, including those set out in applicable Licence(s) and Services and Subsidy Agreement.
- 13.4 Quality of service reports for the USF OFC Services shall be filed by the USF Service Provider with USFCo in accordance with the USF Services and Subsidy Agreement.

#### 14. **Scope of Service**

- 14.1 **USF OFC Services** – The USF OFC Services, which include proposed Bandwidth capacities for each Optic Fiber link included in this Package, shall be provided in the USF Areas in accordance with the USF Services and Subsidy Agreement.
- 14.2 **Optional Services** – In addition to the USF OFC Services, a USF Service Provider may provide other services in the USF Areas, to the extent the USF Service Provider is authorized to provide such services under applicable Licence(s). A USF Service Provider shall be free to apply for additional licences to provide other telecommunications services in accordance with the PTA’s then-current licensing practices and procedures.

#### 15. **Regulation of Operators**

USF Service Providers will remain subject to all other regulatory requirements established from time to time by the PTA, including the terms of all previously granted Licences.

#### 16. **Interconnection and Facilities Sharing**

- 16.1 Interconnection between a USF Service Provider’s network and other licensed telecommunications networks in Pakistan is governed by:
- (a) the Act;
  - (b) the Pakistan Telecommunication Rules, 2000;
  - (c) all applicable licences;
  - (d) the Interconnection Regulations; and
  - (e) the USF Services and Subsidy Agreement.
- 16.2 A USF Service Provider’s network must be technically compatible with all existing transmission networks to ensure properly functioning interconnection. For interconnection purposes, technical compatibility includes, but is not limited to, signalling, routing, synchronization, capacities and network interfaces as applicable.
- 16.3 USF Service Providers shall share infrastructure and essential facilities developed using USF Subsidy funding in accordance with the USF Rules and the USF Services and Subsidy Agreement. The USF Service Provider will provide Optic Fiber connectivity to the un-served Tehsil Headquarters from the nearest City or Town having Optic Fiber connectivity. The Service Provider may co-locate his equipment with the existing Operator or may consider connecting to its own nearest ADM/Repeater.

17. **(Not Applicable)**18. **Type Approval**

Any telecommunications equipment or facilities used in Pakistan by a USF Service Provider shall be subject to the type approval requirements of the Act and any type approval processes established by the PTA pursuant to the Act.

19. **Regulation of USF Service Charges**

19.1 The tariffs charged by a USF Service Provider for the USF OFC Services are subject to requirements under the USF Services and Subsidy Agreement, including that those charges shall not exceed the USF Service Provider's National or Regional tariffs for the same or equivalent services provided in other served locations that are not included in the USF Areas<sup>3</sup>.

19.2 USF Service Providers remain subject to any other tariff regulation by the PTA pursuant to the Act.

20. **Authority to Construct and Use Facilities**

20.1 Subject to the terms of the USF Services and Subsidy Agreement, a USF Service Provider will be authorized to construct or otherwise procure all telecommunications facilities required to provide the USF OFC Services.

20.2 A USF Service Provider may utilise any appropriate Optic Fiber Transmission technology, subject to any limitation in its Licence, in the provision of the USF OFC Services that meet the USF Service requirements identified in the USF Services and Subsidy Agreement.

20.3 All telecommunications facilities and equipment installed by a USF Service Provider as part of the USF Optic Fiber Network shall be:

- (a) new when first installed;
- (b) field-proven (in accordance with section 42.7); and
- (c) compliant with internationally recognized standards.

20.4 Any permissions or authorizations required from authorities in the USF Areas, in connection with the installation/deployment of the USF Optic Fiber Network facilities and equipment shall be the responsibility of the USF Service Provider.

---

<sup>3</sup> See section 2.06 of the Services & Subsidy Agreement.

21. **Requirement to Procure and Manage the USF Network**

A USF Service Provider shall be required to own and operate the USF Network in accordance with the USF Services and Subsidy Agreement.

22. **Transfer or Change of Control**

Transfers and changes in the ownership or control of a USF Service Provider or USF Optic Fiber Network will be subject to USFCo approval in accordance with the USF Services and Subsidy Agreement.

23. **Access to Public and Private Lands**

A USF Service Provider shall have access to public and private lands, including ongoing rights of inspection and entry, in accordance with the Act and all other applicable laws, regulations and rules.

24. **Force Majeure**

A USF Service Provider shall be excused, in accordance with the USF Services and Subsidy Agreement, from certain failures to perform its obligations under the USF Services and Subsidy Agreement if an event of force majeure has prevented the performance of the obligations.

25. **Dispute Resolution**

The USF Services and Subsidy Agreement includes a number of mechanisms to facilitate resolution of disputes, including the appointment by USFCo of a disputes committee consisting of appropriately qualified persons. Where disputes cannot be resolved by application of these mechanisms, parties will continue to have recourse to arbitration and court processes in accordance with the laws of Pakistan.

26. **Technical Auditor**

A Technical Auditor shall be appointed by USFCo in accordance with the USF Services and Subsidy Agreement and other applicable processes. The Technical Auditor may be an appropriately qualified employee of USFCo and/or expert consultant, and will perform identified functions in accordance with the USF Services and Subsidy Agreement including:

- (a) certification that Project Implementation Milestones have been achieved and services have been provided as per specifications and that USF Subsidy payments are therefore due;
- (b) certification that events of force majeure have prevented the performance of certain obligations under the USF Services and Subsidy Agreement; and
- (c) proposing amendment of the USF Areas, and any related amendments to the agreement, upon the occurrence of a certified event of force majeure.

27. **Compliance with Law**

A USF Service Provider shall be required to comply with all laws of Pakistan applicable to its USF OFC Services activities at all times, including the Act, all regulations, rules, orders, decisions and guidelines issued under the Act.

28. **Term of USF Services and Subsidy Agreement**

The USF Services and Subsidy Agreement shall have a term of ten (10) years, commencing from the effective date of the agreement.

29. **Other Obligations under USF Services and Subsidy Agreement**

The USF Services and Subsidy Agreement contains specific obligations of the USF Service Provider, including obligations regarding the roll-out of the USF Optic Fiber Network and provision of the USF OFC Services. The agreement also includes specific remedies for non-performance, including drawing on the Performance Bond or exercising the lien on USF Optic Fiber Network assets, as well as insurance requirements, indemnification, and USF Service Provider representations and warranties.

30. **Fees Payable by the USF Service Provider**

A USF Service Provider will be responsible for paying any fees, taxes or charges otherwise applicable to the USF Service Provider in relation to its provision of the USF OFC Services, in accordance with the Act and other laws of Pakistan and regulations made thereunder.

31. **(Not Applicable)**

**End of Part II**



## **Part III**

### **Instructions to Applicants**

#### **32. Selection of Successful Applicant**

USFCo plans to execute a USF Services and Subsidy Agreement with the Applicant whose Proposal meets the following selection criteria:

- (a) the Proposal demonstrates that the Applicant is a “Qualified Applicant”, meeting the requirements of sections 34, 35, 36 and 37 of this RFA;
- (b) the Proposal is “responsive”, meeting the requirements identified in section 40.1 of this RFA; and
- (c) the Applicant proposes the lowest USF Subsidy for the defined USF Areas.

#### **33. Pre-proposal Meeting**

- 33.1 USFCo shall conduct a “pre-proposal meeting” at the office of USFCo unless otherwise directed. The purpose of the meeting will be for USFCo to provide answers to the written questions posed and comments made by potential Applicants (see sections 56.5 and 56.6 regarding the submission of questions and comments), and to otherwise clarify or amend the RFA Process and related documentation. All authorised representatives of potential Applicants shall be entitled to attend the meeting.
- 33.2 USFCo will keep a register of all those who are present at the pre-proposal meeting. All representatives from the Applicants and USFCo attending the meeting shall sign the register.
- 33.3 USFCo will prepare minutes of the pre-proposal meeting. The minutes, and the text of any written questions and answers from Applicants, will be published by USFCo on the USFCo website.
- 33.4 Responses to the written questions and results of the pre-proposal meeting shall not constitute an amendment to the RFA documents or the RFA Process unless USFCo re-issues the affected RFA documents with a specific identification of the resulting amendments.
- 33.5 Any amended RFA documents thus issued shall become the applicable statement of the RFA Process, and shall be communicated in writing to all Applicants. Applicants shall promptly acknowledge receipt of any amended documents by email to the USFCo project administrator identified in section 9.1.
- 33.6 USFCo may extend the deadline for submission of Proposals as required to give Applicants reasonable time in which to take account of any amended RFA documents

34. **Qualification Criteria**

- 34.1 USFCo will determine whether an Applicant qualifies as a Qualified Applicant for the purposes of the award of a USF Services and Subsidy Agreement.
- 34.2 For the purpose of this RFA the qualification criteria are described in sections 35, 36 and 37.

35. **Financing Capacity**

- 35.1 The Applicant must satisfy USFCo that the proposed USF Service Provider has sufficient financing capacity for the investments required to construct the USF Optic Fiber Network and to provide the USF OFC Services. The criteria to determine whether an Applicant has sufficient financing capacity for a project of this size are:
- (a) A net worth of not less than PKR 300,000,000 (Pak Rupees Three Hundred Million only); or
- (b) Possession or access to a line of credit equal to PKR 300,000,000 (Pak Rupees Three Hundred Million only).
- 35.2 The net worth of any shareholder in the proposed USF Service Provider may be included in the calculation of the net worth of the proposed USF Service Provider for the purposes of sections 35.1 and 42.5 if:
- (a) The shareholder holds or will hold a minimum of 1/3 (one third) of the ownership interest (including all forms of ownership interest) in the USF Service Provider; and
- (b) The shareholder indicates that it is willing to guarantee the performance of the USF Service Provider and provides a written undertaking to this effect for inclusion in the Proposal.

36. **Operational Experience**

- 36.1 The Applicant must have operated a telecommunications network that meets all of the following requirements:
- (a) The network has a transmission backbone component for OFC; services .
- (b) The network includes physical transmission facilities, such as wires, cables, or optic fiber systems owned and operated by the USF Service Provider; and
- (c) The network has been operated by the USF Service Provider for a minimum of one (1) year.

- 36.2 In complying with section 36.1 above , the Applicant may rely on:
- (a) the operational experience of the USF Service Provider it proposes; or
  - (b) the experience of any Person that is a member of the Applicant’s bidding consortium, and that:
    - (i) is licensed by the PTA; and
    - (ii) is a shareholder in the proposed USF Service Provider, or
    - (iii) has committed in a binding agreement to become a shareholder in the proposed USF Service Provider,

provided that the Person holds or will hold a minimum of 1/3 (one third) of the ownership interests (including all forms of ownership interests) in the USF Service Provider.

37. **Applicant Eligibility**

- 37.1 The Applicant must demonstrate that the proposed USF Service Provider is eligible to receive the USF Subsidy pursuant to the World Bank Procurement Guidelines. An extract from the World Bank Procurement Guidelines, and related information, is included as Annex 3 to this RFA<sup>4</sup>.
- 37.2 As indicated elsewhere in this RFA, the Applicant must be a USF Contributor. In the case of a Consortium Applicant, the Consortium Applicant leader must be a USF Contributor.
- 37.3 The Applicant must also not have any “conflict of interest”, this meaning any association with consultants or other advisors retained by USFCo or GoP to advise on the design or implementation of the RFA Process; or participating in more than one Proposal in this RFA Process.
- 37.4 The USF Service Provider proposed by the Applicant must be incorporated under the Companies Ordinance, 1984.
- 37.5 The Applicant must possess valid Licence(s) for the relevant region and telecommunication services, issued by PTA. The Applicant must satisfy USFCo that the proposed USF Service Provider is in substantial compliance with the conditions of its Licence(s). In complying with this requirement, the Applicant may rely on the Licence(s) of any shareholder in the USF Service Provider that meets the requirements of section 35.2.

---

<sup>4</sup> Only applicable if Project is financed by World Bank

38. **Consortium Applicant**

38.1 Any USF Contributor leading a consortium may bid for any USF Subsidy on behalf of that consortium (“Consortium Applicant”) under conditions similar to those set out for an individual USF Applicant, provided that the consortium’s composition and Proposal materials satisfy the consortium requirements identified below:

38.1.1 There shall be no limit on the number of members of the consortium, except that:

- (a) the consortium shall include at least one USF Contributor; and
- (b) the consortium shall include at least one LL, WLL, Cellular Mobile or LDI licence holder; but shall include no more than one LL, WLL, Cellular Mobile or LDI licence holder.

38.1.2 One member of the consortium shall be identified as the consortium leader. The consortium leader shall be the USF Contributor member of the consortium. The consortium leader shall also enter into all contracts on behalf of the consortium and shall otherwise be responsible for consortium performance.

38.1.3 Notwithstanding section 38.1.2, all members of the consortium shall be jointly and severally liable to USFCo in respect to the performance of the USF Services and Subsidy Agreement.

39. **Bid Bond**

39.1 The Bid Bond shall remain valid for a minimum period of 210 days from the closing date identified in section 46.3. USFCo will not be obligated or liable to pay any accumulated interest on the Bid Bond.

39.2 The Bid Bond of all unsuccessful Applicants, other than the Qualified Applicant that has submitted the next lowest USF Subsidy proposal for the USF Areas, will be released not later than 30 days after USFCo issues a Letter of Intent pursuant to section 53.1.

39.3 The successful Applicant’s Bid Bond, and the Bid Bond of the Qualified Applicant that has submitted the next lowest USF Subsidy proposal for the USF Areas, will be released not later than 30 days after: i) the execution of the USF Services and Subsidy Agreement; and ii) furnishing of the Performance Bond pursuant to section 54.

39.4 Notwithstanding section 39.3, the Bid Bond shall be forfeited by an Applicant in any of the following cases:

- (a) the Applicant withdraws its Proposal prior to execution of the USF Services and Subsidy Agreement;

- (b) where the successful Applicant has received from USFCo a Letter of Intent to execute the USF Services and Subsidy Agreement and the USF Service Provider proposed by the Applicant fails or refuses to submit the Performance Bond in accordance with sections 53 and 54 of this RFA;
- (c) if after the issuance of the Letter of Intent USFCo determines that Applicant is disqualified pursuant to section 51.1 of the RFA; and
- (d) the USF Service Provider proposed by the successful Applicant does not execute the USF Services and Subsidy Agreement within 30 days of receipt of LOI.

#### 40. **Responsiveness of Proposals**

- 40.1 A Proposal will be considered responsive only if all of the following requirements are met:
  - (a) The Proposal is submitted by an Applicant (or any company or other Person identified in the Proposal as a member or participant in a Consortium Applicant) that has registered with USFCo and purchased an official copy of the RFA in accordance with the Notice of Request for Applications document issued by USFCo.
  - (b) The Proposal is complete and submitted in accordance with all the requirements of this RFA, including the content requirements identified in sections 41, 42 and 43 and the submission requirements identified in sections 45 and 46.
  - (c) The Proposal is received before the closing date and time for submission identified in section 46.3.
- 40.2 Proposals that do not comply substantially with the above requirements will be rejected as non-responsive.

#### 41. **Content and Format of Proposals**

Bid shall be well formatted starting with Table of Contents referring page numbers. Colored separators, tags or flags shall be used to identify different sections/items of Table of Contents stacked in to Box Files.

- 41.1 Each Proposal shall be assembled in two separate parts, contained in separate and clearly marked envelopes, as follows:
  - (a) **Part 1** - “Qualifications and Service Proposal”, setting out information about the Applicant, the USF Service Provider proposed by the Applicant, the USF Optic Fiber Network and the USF OFC Service proposal of the Applicant; and

- (b) **Part 2** - “USF Subsidy Proposal”, which shall set out the proposed USF Subsidy amount for the USF Areas.

41.2 The required content and form of each Part of the Proposal are outlined in more detail below. All parts of the Proposal must be printed using indelible ink.

42. **Part 1 Structure Requirements – Qualifications and Service Proposal**

Part 1 of the Proposal shall include the following documents and information:

42.1 **Cover Letter and Attachments**

- (a) The cover letter and each page of the attached proposal materials must be signed by a person or persons duly authorised to act on behalf of the Applicant. Where the Applicant is a consortium, the cover letter and attachments must be signed by a person or persons duly authorised to act on behalf of each member of the consortium.
- (b) The cover letter must provide a summary description of the Applicant, including the members of any Consortium Applicant, and of the USF Service Provider proposed by the Applicant.
- (c) The cover letter must indicate a firm commitment to engage in final negotiation of the USF Services and Subsidy Agreement promptly and in good faith.
- (d) The cover letter must confirm that the Proposal is open for acceptance by USFCo for 180 (one hundred and eighty) days from the bid closing date identified in section 46.3 of this RFA.
- (e) Attached to the cover letter must be one or more Powers of Attorney or notarised certificates that clearly evidence the authority of the signatory (ies) of the cover letter and other documents submitted with the Proposal which require signature on behalf of the Applicant, a shareholder of the Applicant, the members of the Applicant consortium, if applicable, or the USF Service Provider proposed by the Applicant.
- (f) Also included with the cover letter, must be the Bid Bond in the form of Annex 2 to this RFA, in accordance with the following requirements:
  - (i) The Applicant shall furnish a Bid Bond in the minimum amount of PKR 1,500,000 (Pak Rupees One Million and Five Hundred Thousand only) in the form of Annex 2 to this RFA and issued by a reputable bank located in Pakistan that is acceptable to USFCo.
  - (ii) The Applicant shall complete the Bid Bond in the form included in Annex 2. The form must be completed without alterations to its format, and no

substitutes shall be accepted. All blank spaces shall be filled in with the information requested.

- (iii) The Bid Bond of a consortium must be in the name of the lead member of the consortium.

#### 42.2 **Information and Documentation on the Applicant**

- (a) The name, legal status, registered office address and a description of the business of the proposed USF Service Provider.
- (b) The name, legal status, registered office address and a description of the business of all shareholders in the proposed USF Service Provider.
- (c) The name, legal status and registered office address of any Person who Controls the proposed USF Service Provider.
- (d) The name, legal status and registered office address of all Persons who own, directly or indirectly, any ownership interest in a shareholder of the proposed USF Service Provider.
- (e) The name, country of citizenship and address of each Person who is a director of the proposed USF Service Provider.
- (f) A chart:
  - (i) showing the ownership structure of the proposed USF Service Provider;
  - (ii) illustrating the relationship among all Persons having a direct or indirect ownership interest; and
  - (iii) specifying the nature and level of such ownership interest.
- (g) A description of the legal status of the proposed USF Service Provider, including:
  - (i) a certified copy of its certificate of incorporation, Memorandum and Articles of Association;
  - (ii) a certified copy of a resolution of the Board of Directors of the USF Service Provider that authorizes the Applicant to submit the Proposal and propose the USF Service Provider for the USF Services and Subsidy Agreement; and
  - (iii) any shareholder agreement, joint venture agreement or Memorandum of Understanding, or other arrangement of any kind between the shareholders of the proposed USF Service Provider.
- (h) In the case of companies with shares listed on a stock exchange, the information regarding shareholders required in sections 42.2(b), 42.2(d)

and 42.2(f) must be provided only to the best of the Applicant's knowledge and only in respect of shareholders owning more than 10% (ten percent) of the issued shares.

#### 42.3 Information to be Submitted by a Consortium Applicant

In the case of a Consortium Applicant, the Consortium Applicant's Proposal shall also include:

- (a) the name, legal status, registered office address and a description of the business of all Persons with a direct or indirect ownership interest of more than 10% (ten percent) in the Consortium Applicant or in any member of the consortium;
- (b) where a consortium member is an individual, identification and proof of citizenship for that individual;
- (c) specific details of the structure of the consortium, including identification of the lead member of the consortium; and
- (d) the agreement(s) establishing the consortium, specifying at least:
  - (i) a clear allocation of responsibilities and confirmation that all members of the consortium will be jointly and severally liable to USFCo in respect of performance of the USF Services and Subsidy Agreement;
  - (ii) the duration of the consortium agreement;
  - (iii) details of the ownership interests in the consortium and the financial contributions of each member; and
  - (iv) arrangements governing managerial control by the consortium over the operation of the USF Service Provider.

#### 42.4 Documentation on the Applicant's Licence(s)

To demonstrate substantial compliance with the conditions of existing Licence(s), the Applicant shall submit:

- (a) a copy of each Licence issued by the PTA to the proposed USF Service Provider, or to any shareholder of the USF Service Provider that meets the requirements of section 35.2;
- (b) a copy of the most recent renewal of any such Licence; and
- (c) a declaration in the form of Annex 4 to this RFA, representing that the Applicant is in compliance with all applicable licence conditions, and is otherwise in good standing with the PTA.



#### 42.5 **Documentation on Financial Resources of the Applicant**

- (a) Financial statements of the proposed USF Service Provider for the preceding two years, including an income statement and balance sheet, prepared in accordance with internationally accepted accounting standards; or
- (b) If the proposed USF Service Provider has not existed, or has not received service revenues, for at least two years prior to the submission of the Proposal, the financial statements of any shareholder that meets the requirements of section 35.2 must be provided. The financial statements of said shareholder must be provided for the preceding two years and must be prepared in accordance with internationally accepted accounting standards.

#### 42.6 **Documentation on Operational Experience of the Applicant**

- (a) Where the Applicant will rely on the experience of a Person identified in section 36.2, the Applicant must demonstrate that arrangements are in place to provide the proposed USF Service Provider with access to the technology, professional know-how and operational experience required to operate the USF Optic Fiber Network and to provide the USF OFC Services. Specifically, the Proposal must include:
  - (i) a statement that identifies the Person;
  - (ii) documentation that clearly demonstrates that the relationship between the proposed USF Service Provider and such Person meets the requirements of section 36.2(b);
  - (iii) a written commitment from said Person to participate in the USF Service Provider's operations;
  - (iv) a description of such proposed participation, which must clearly demonstrate to USFCo's satisfaction that the Person will have a significant and continuing participation in running the operations of the USF Service Provider for the life of the USF Services and Subsidy Agreement; and
  - (v) approval in writing by the Person's Board of Directors of the commitment and description of the Person's proposed participation.
- (b) The Proposal shall include specific information regarding the telecommunications markets in which the proposed USF Service Provider (or, if its experience is relied upon, the Person identified in section 36.2) has operated in the manner described. Details should be provided concerning:
  - (i) the number of years of operation;

- (ii) the telecommunications management experience of the proposed USF Service Provider;
  - (iii) the types of telecommunications services provided; and
  - (iv) the experience of the proposed USF Service Provider in rolling out a telecommunications network.
- (c) The operational experience listed in section 36.1 above shall constitute experience of only one Person and not the aggregate experience of two or more Persons.

#### 42.7 **Field Proven Equipment, Software and Solutions**

- (a) All proposed equipment and software shall have been satisfactorily field-proven in actual service. To meet this requirement, the proposed suppliers shall have supplied equipment and software of the type described in the Proposal to at least two telecommunications network operators and the equipment and software shall have been in satisfactory service with those telecommunications network operators for a minimum period of one year prior to the date of submission of the Proposal.
- (b) The Applicant shall provide the technical specifications of the major types of equipment and software to be supplied, installed and operated in order to provide the USF OFC Services,.
- (c) The Applicant shall submit evidence that the proposed suppliers of the equipment, identified pursuant to sub-section (a) above, have been in the business of manufacturing telecommunications equipment for at least three years before the date of the Proposal.
- (d) The Applicant shall submit the names, addresses, telephone numbers and fax numbers of the two network operators referred to in sub-section (a) above. The Applicant shall also submit letters from either the proposed equipment suppliers or the two network operators certifying satisfactory performance of the proposed equipment and software. USFCo reserves the right to verify the quality of the equipment and software and its satisfactory performance in actual service with the two network operators.
- (e) In view of the rapid technological development in communications technology, hardware and software, Applicants may propose that the USF Service Provider will install updated versions of the equipment and software in actual service. Applicants shall provide full details of the technological changes introduced in the proposed equipment and software.

- (f) All solutions and practices followed to provide telecommunication services shall be in accordance to the international standards defined by ITU-T. The solutions and practices must be well known and observed by the Industry.
- (g) As an alternative to meeting the requirements of sub-sections (a), (c) and (d) above, the Applicant must demonstrate satisfactory performance of the proposed equipment and software as part of the operations it has identified pursuant to section 36.1 of this RFA for a minimum period of one year prior to the date of submission of the Proposal.

#### 42.8 Network Description

- (a) The Applicant must provide a concise description of the planned network of the proposed USF Service Provider. The description must demonstrate that the proposed USF Optic Fiber Network will meet the requirements specified in the USF Services and Subsidy Agreement, including, but not limited to, the USF OFC Services specifications in Schedules A and B to that agreement. The network description provided by the Applicant must also clearly demonstrate that the USF Service Provider will:
  - (i) extend Optic Fiber transmission facilities into the USF Areas, with sufficient planned capacity to meet the requirements of the USF OFC Services; and
  - (ii) provide proposed bandwidth capacities to all Tehsil Headquarters or towns identified in Schedule C of the USF Services and Subsidy Agreement as being mandatory for USF Optic Fiber Network and USF OFC Services.
- (b) The network description shall include:
  - (i) a description of the Optic Fiber transmission network, interface technology to be employed, including applicable technical standards, and a network map illustrating the intended network architecture and USF Optic Fiber Network installations;
  - (ii) a summary description of the roll-out and service provision plans for the USF Optic Fiber Network and USF OFC Services, that meet or exceed the Project Implementation Milestones;
  - (iii) (Not Applicable);
  - (iv) the specific USF Optic Fiber Network bandwidth capacity estimated by the Applicant as required to meet traffic requirements in the USF Areas

over the first five years of commercial operations, and how that capacity will be provided by the USF Service Provider;

- (v) **proposed interconnection points.** The Applicant should specify how it intends to plan and build the USF Optic Fiber network identifying specific interconnection points for smooth flow of intelligence in upward and downward modes.
- (vi) the Applicant shall also provide the information identified in the “Design Parameters” included in Annex 5.

42.9 **Operations Description** - The Proposal must include:

- (a) a general description of the intended operations of the USF Service Provider, including its general approach to implementation of the USF Optic Fiber Network and provision of the USF OFC Services; and
- (b) a brief description of any land or rights in land (i.e., rights of way) that must be acquired for the operations, the estimated cost of acquiring such land or rights in land and the impact acquiring such rights might have on the Applicant’s network roll-out plan.

42.10 **Quality of Service Description** - The Proposal must include a summary of the methodology and processes that will be implemented by the proposed USF Service Provider to meet the service requirements and quality of service standards identified in Schedules A and B to the USF Services and Subsidy Agreement, including performance monitoring, reporting and fault resolution processes.

42.11 **Tariffs and Charges** - The Proposal must include a statement by the Applicant confirming that its tariffs and service charges for the USF Services will meet the tariff requirements identified in the USF Services and Subsidy Agreement.<sup>5</sup>

42.12 **Additional Information**

- (a) The Applicant’s comments on the draft USF Services and Subsidy Agreement or any other transaction documents or requirements, including particularly any terms or conditions that the Applicant cannot or will not comply with; and
- (b) Any information that does not specifically respond to this RFA, but that the Applicant thinks is relevant to the Proposal.

43. **Part 2 Subsidy Proposal**

Information to be submitted by the Applicant in Part 2 of its Proposal:

---

<sup>5</sup> See Section 2.06 of the Agreement.

- (a) **Subsidy Proposal** – The Applicant must provide a completed USF Subsidy Proposal Form prepared in accordance with Annex 1 to this RFA. As indicated in Annex 1, the amount of the proposed USF Subsidy and total cost of the Project shall be set out in words and numbers and in the event of any discrepancy between the words and numbers, the amount set out in words shall govern, and the currency of the proposed USF Subsidy shall be stated in PKR.
- (b) **USF Areas** – The Applicant’s USF Subsidy Proposal must state the proposed amount of USF Subsidy for implementation of the USF Network and delivery of the USF Services throughout the USF Areas.
- (c) **Calculation of Subsidy** – The Proposal must include a concise financial analysis detailing the calculation of the proposed USF Subsidy amount. The information furnished in this regard will be kept strictly confidential by USFCo; however, and as indicated in section 47.2, USFCo shall be entitled to publicly announce the total amount of each Applicant’s USF Subsidy Proposal. The financial analysis must clearly demonstrate the breakdown of projected USF Optic Fiber Network costs, itemized to show the costs of the USF Optic Fiber Network components identified pursuant to section 42.8, per each link.
- (d) **Projected Financial Statements** - The Applicant must provide projected financial statements for years one through five of the USF Service Provider, including an income statement, balance sheet and statements of sources and application of funds for the USF Service Provider prepared in accordance with internationally accepted accounting standards. For this purpose, the financial statements shall treat the USF Subsidy amount as if it were part of the debt, equity or deferred income of the USF Service Provider<sup>6</sup>. The financial statements shall include projections of fee revenues from the USF OFC Services and any Optional Services.

#### 44. **Compliance Checklist**

- 44.1 A “Compliance Checklist” is attached as Annex 5 to this RFA. Applicants must include a completed Compliance Checklist in each copy of their Proposals.
- 44.2 When completing the Compliance Checklist, Applicants must identify the specific parts and page numbers of their Proposals that correspond to the documents and information required by the RFA sections identified in the Compliance Checklist. Applicants must also specifically identify and comment on any of the identified RFA sections for which their Proposals are either “Non-Compliant” or only “Partially Compliant”.

---

<sup>6</sup> Applicants must take care that the USF Subsidy amount included in the financial statements is aggregated with other funds so that the amount of the Applicant’s intended subsidy cannot be specifically identified.

44.3 Without derogating from the provisions of sections 44.1 and 44.2, above, in the event of any discrepancy between the Proposal requirements described in this RFA and the Compliance Checklist, the terms and requirements of this RFA shall prevail.

45. **Submission of the Proposal**

45.1 The Applicant shall prepare three copies of the Proposal, clearly marking the first copy “Original Proposal” and the 2<sup>nd</sup> & 3<sup>rd</sup> copies “Copy of Proposal”.

45.2 The Applicant shall also prepare one electronic copy of the Proposal (i.e., a CD-ROM or DVD containing copy of the Proposal that is in a format readable by Microsoft Office or Adobe Acrobat software).

45.3 All copies of the Proposal shall be clearly marked with the name of the Applicant.

45.4 In the event of any discrepancy between copies, the original shall govern.

45.5 As indicated in section 41, the Proposal consists of two separate parts: Part 1, the Qualification and Service Proposal; and Part 2, the USF Subsidy Proposal. Each part of the Proposal shall be separated into clearly labelled envelopes, with each envelope containing the three hard copies and the single CD-ROM or DVD copy of the applicable part of the Proposal. The envelopes containing the separate parts of the Proposal shall be packaged together in a single box or other container. The container shall be sealed; that is securely packed and closed, so that it is not possible to open it without visual evidence thereof.

45.6 Each Proposal package shall be clearly marked with the following information:

Proposal to Provide USF Telecommunications Services (Optic Fiber Connectivity with Tehsil HQs)

Name of Applicant:

Local Contact Name, Phone Number and E-Mail Address:

*“DO NOT OPEN, EXCEPT IN PRESENCE OF USFCo EVALUATION COMMITTEE”*

45.7 USFCo will provide a written receipt confirming the delivery of each Proposal received prior to the closing date and time.

45.8 The Bid Bond should be enclosed in a separately sealed envelope clearly marked with the name of the Applicant and the text “Bid Bond”. This envelope should be included in the container that includes all Proposal

contents (see section 45.5), and delivered with the assembled Proposal package.

46. **Delivery of the Proposal**

- 46.1 The Proposal packages shall be delivered at the address identified in Annex 8 of RFA before the closing date and time mentioned in section 46.3.
- 46.2 If the Proposal container is not sealed and marked properly, USFCo will assume no responsibility for the Proposal or the disposition of its contents. Improperly marked or sealed packages may be rejected by USFCo.
- 46.3 **Closing Date for Submission of the Proposal** - The sealed Proposal package shall be delivered to USFCo at the address specified in section 46.1 no later than date and time identified in Annex 8 of this RFA.
- 46.4 **Late Proposal** - Proposals received after the closing date and time identified in section 46.3 will be returned to the Applicant(s).

47. **Opening of Proposals**

- 47.1 USFCo will publicly open the duly received Proposals, in the presence of authorised representatives of any Applicants who desire to attend, at least thirty minutes after the deadline for submission of bids identified in section 46.3, in the conference room of USFCo, 5th Floor HBL Tower, Jinnah Avenue, Islamabad. The opening will proceed whether one or more representatives of Applicants are present or absent. Following opening of the Proposals, USFCo will proceed with evaluation of the Proposals in accordance with section 48.
- 47.2 All Proposals shall be opened one at a time, with a representative of USFCo reading out the name of the Applicants and any other Applicant information that USFCo may consider appropriate. Only Proposals opened and read out at the proposal opening shall be considered for further evaluation, irrespective of the circumstances. No Proposals shall be rejected at Bid opening except for late Proposals or any Proposals that are not accompanied by a Bid Bond.
- 47.3 USFCo shall prepare a record of the initial Proposal opening that shall include, at a minimum, the name of the Applicant, the presence or absence of a Bid Bond and identification of any Proposals rejected for late submission. The Applicants' representatives who are present shall be requested to sign an attendance sheet. A copy of the record shall be distributed to all Applicants.



#### 48. **Selection Process and Evaluation of Proposals**

- 48.1 Subject to any request for clarification submitted by USFCo pursuant to section 56.7, the information submitted by Applicants in response to this RFA will be the sole basis for the selection of the USF Service Provider. Provided that the Proposal is substantially responsive, GoP and USFCo reserve the right to request Applicants to provide additional information and documents to assist them in evaluating the Proposals. However, neither the GoP nor USFCo, nor any other GoP body, will assist Applicants to supplement Proposals which are otherwise deficient or non-compliant. Failure to provide additional information within the identified timeframe may result in the Applicant's proposal being determined to be non-compliant.
- 48.2 USFCo will review each Applicant's "Qualifications and Service Proposal" (Part 1 of the Proposal) to determine whether or not each Applicant is a Qualified Applicant within the meaning of section 34 of this RFA. Applicants that fail to satisfy the criteria identified in section 34 for becoming a Qualified Applicant will be rejected. USFCo will identify the grounds for rejection in a letter to each Applicant that fails to qualify as a Qualified Applicant.
- 48.3 USFCo will open and review each Qualified Applicant's "USF Subsidy Proposal" (Part 2 of the Proposal). USFCo will identify the date and time of opening the USF Subsidy Proposals, and representatives of Qualified Applicants will be entitled to attend the opening of the USF Subsidy Proposals. The representatives of Qualified Applicants who are present at the opening shall be requested to sign an attendance sheet. A representative of USFCo shall read out or otherwise announce the amount of USF Subsidy proposed by each Qualified Applicant. USFCo will prepare minutes for the USF Subsidy Proposal opening meeting. The minutes will be sent to all Qualified Applicants and will be published by USFCo on its website.
- 48.4 **Awarding USF Services and Subsidy Agreement** – Subject to section 60, the USF Services and Subsidy Agreement will be awarded to the Qualified Applicant that proposes the lowest USF Subsidy for the USF Areas.
- 48.5 **Ties** - In the event that there is more than one Qualified Applicant bidding the lowest USF Subsidy for one or more USF Areas, USFCo shall proceed as follows:
- (a) The tied Qualified Applicants will receive written notice of the tie and instructions for submission of second round bids.
  - (b) The tied Qualified Applicants will proceed to a second round of bidding in which they will submit new USF Subsidy Proposals that comply with the requirements of section 43.



- (c) The new USF Subsidy Proposal amount submitted by the tied Qualified Applicant must be smaller than or equal to the original USF Subsidy Proposal amount submitted by the Qualified Applicant.
  - (d) The new USF Subsidy Proposals shall be delivered in a sealed envelope, that is, securely closed so that it is not possible to open it without visual evidence thereof, to the address identified in section 46 and before the date and time specified in the written notice referred to in section 48.5(a). New USF Subsidy Proposals will not be accepted after the date and time specified in the written notice referred to in section 48.5(a).
- 48.6 USFCo's determinations in the evaluation process shall be final and binding upon Applicants, subject to the laws of Pakistan.

49. **Fraud or Corruption**<sup>7</sup>

It is the World Bank's policy to require that Borrowers (including beneficiaries of Bank loans), as well as bidders, suppliers, and contractors and their subcontractors under Bank-financed contracts, observe the highest standard of ethics during the procurement and execution of such contracts.<sup>8</sup> In pursuance of this policy, the World Bank:

- (a) defines, for the purposes of this provision, the terms set forth below as follows:
  - (i) "corrupt practice"<sup>9</sup> is the offering, giving, receiving or soliciting, directly or indirectly, of anything of value to influence improperly the actions of another party;
  - (ii) "fraudulent practice"<sup>10</sup> is any act or omission, including a misrepresentation, that knowingly or recklessly misleads, or attempts to mislead, a party to obtain a financial or other benefit or to avoid an obligation;

---

<sup>7</sup> This section would apply in substance. However, the references to the Bank would be applicable only if the project is financed by the World Bank.

<sup>8</sup> In this context, any action taken by a bidder, supplier, contractor, or a sub-contractor to influence the procurement process or contract execution for undue advantage is improper.

<sup>9</sup> "Another party" refers to a public official acting in relation to the procurement process or contract execution. In this context, "public official" includes World Bank staff and employees of other organizations taking or reviewing procurement decisions.

<sup>10</sup> In this context, a "party" refers to a public official; the terms "benefit" and "obligation" relate to the procurement process or contract execution; and the "act or omission" is intended to influence the procurement process or contract execution.

- (iii) “collusive practice”<sup>11</sup> is an arrangement between two or more parties designed to achieve an improper purpose, including to influence improperly the actions of another party;
- (iv) “coercive practice”<sup>12</sup> is impairing or harming, or threatening to impair or harm, directly or indirectly, any party or the property of the party to influence improperly the actions of a party;
- (v) “obstructive practice” is
  - a. deliberately destroying, falsifying, altering or concealing of evidence material to the investigation or making false statements to investigators in order to materially impede a Bank investigation into allegations of a corrupt, fraudulent, coercive or collusive practice; and/or threatening, harassing or intimidating any party to prevent it from disclosing its knowledge of matters relevant to the investigation or from pursuing the investigation, or
  - b. acts intended to materially impede the exercise of the Bank’s inspection and audit rights.
- (b) will reject a proposal for award if it determines that the Bidder recommended for award has, directly or through an agent, engaged in corrupt, fraudulent, collusive, coercive or obstructive practices in competing for the contract in question;
- (c) will cancel the portion of the loan allocated to a contract if it determines at any time that representatives of the Borrower or of a beneficiary of the loan engaged in corrupt, fraudulent, collusive, or coercive practices during the procurement or the execution of that contract, without the Borrower having taken timely and appropriate action satisfactory to the Bank to remedy the situation;
- (d) will sanction a firm or individual, including declaring them ineligible, either indefinitely or for a stated period of time, to be awarded a Bank-financed contract if it at any time determines that they have, directly or through an agent, engaged in corrupt, fraudulent, collusive, coercive or obstructive practices in competing for, or in executing, a Bank-financed contract; and
- (e) will have the right to require that a provision be included in bidding documents and in contracts financed by a Bank Loan, requiring bidders, suppliers, contractors and consultants to permit the Bank to inspect their accounts and records and other documents relating to the Bid

---

<sup>11</sup> “Parties” refers to participants in the procurement process (including public officials) attempting to establish bid prices at artificial, non competitive levels.

<sup>12</sup> In this context, a “party” refers to a participant in the procurement process or contract execution.

submission and contract performance and to have them audited by auditors appointed by the Bank.

50. **Period of Validity of Proposal**

The Proposal shall remain valid for 180 days from the closing date identified in section 46.3 of this RFA.

51. **Grounds for Rejection of Proposal**

51.1 USFCo shall reject Proposals and remove them from further consideration for any of the reasons set out below:

- (a) Failure to comply with any of the procedures or other requirements identified in sections 35, 36, 37, 40, 42, 43 and 45 of this RFA.
- (b) Failure to submit the Bid Bond amount specified in this RFA.
- (c) Serious inaccuracy or misrepresentation of any material facts in any part of the Proposal.
- (d) Default by a USF Contributor in making USF contribution payments.
- (e) The Applicant submitting the Proposal is determined by USFCo to have a conflict of interest (as that term is defined in section 37.3).

51.2 On the occurrence of any of the forfeiture events identified above in section 51.1, USFCo shall be entitled to select another Applicant. In such an event, USFCo may award the USF Services and Subsidy Agreement to the USF Service Provider proposed by the Qualified Applicant that proposed the next lowest USF Subsidy for the USF Areas for which the first-selected Applicant proposed the lowest USF Subsidy. Where the USF Subsidy is financed by the Bank pursuant to the Loan (see sections 2.2 and 2.3), the award of the USF Services and Subsidy Agreement shall be subject to prior consultation with, and the absence of objection by, the **Bank**.

52. **Subsequent Disqualification and Ineligibility**

52.1 If evidence of any of the activities referred to in sub-sections 51.1 (c) through (e) is disclosed after the USF Services and Subsidy Agreement has been executed, USFCo may terminate the USF Services and Subsidy Agreement without compensation. Disclosure of such evidence will also entitle the Bank or other institution of the **World Bank**<sup>13</sup> to decline to finance the USF Subsidy, and for USFCo to seek repayment of any part of the USF Subsidy that may have been paid. The provisions of this section are in addition to any criminal or civil legal action which may be

---

<sup>13</sup> Only applicable if Project is financed by World Bank.

available to or taken by any government or regulatory authority, including PTA and USFCo.

- 52.2 USFCo will declare an Applicant ineligible, either indefinitely or for a stated period of time, to be awarded a USFCo financed contract if it at any time it determines that the Applicant has engaged in corrupt, fraudulent, collusive or coercive practices in applying for, or in performing, a USFCo financed contract.

53. **Letter of Intent**

- 53.1 USFCo will issue a Letter of Intent (“LOI”) to the successful Qualified Applicant to confirm USFCo’s intention to grant the USF Services and Subsidy Agreement to the USF Service Provider proposed by the Applicant. The LOI will also require the USF Service Provider proposed by a successful Applicant to submit the required Performance Bond within 10 days of receipt of the LOI.
- 53.2 If the USF Service Provider proposed by the Applicant to whom the LOI is directed does not submit the required Performance Bond within 10 days from the date of receipt of the LOI, USFCo may:
- (a) Cause the Applicant to forfeit the Bid Bond pursuant to section 39.4 above;
  - (b) Disqualify the Applicant and the USF Service Provider proposed by the Applicant; and
  - (c) Issue another LOI to the Qualified Applicant that has submitted the next lowest USF Subsidy proposal for the USF Areas.
- 53.3 An Applicant to whom a LOI is directed must accept the LOI by notice in writing (the “Letter of Acceptance”) to USFCo within seven (7) days from the date of receipt of the LOI.
- 53.4 It is the intention of USFCo that the USF Services and Subsidy Agreement (the “Contract”) will be finally negotiated and signed within 30 days of the date of receipt of the LOI. In the event that USFCo and the recipient of the LOI are unable to finalize the terms of the Contract within the 30 day period, USFCo shall be entitled to terminate negotiations, return the Performance Bond and issue another LOI to the Qualified Applicant that has submitted the next lowest USF Subsidy proposal for the USF Areas.
- 53.5 Once the Contract has been entered into with the USF Service Provider put forward by the winning Applicant, USFCo shall publish the results of the RFA Process including at least the following information: (i) name of each Applicant who submitted a Proposal; (ii) name of Applicants whose Proposals were rejected, and the reason(s) for their

rejection; (iii) the USF Subsidy Proposal amounts as read out at the subsidy proposal opening; (iv) the name of the winning Applicant; and (v) a summary of the resulting Contract. The information shall also be published on USFCo's website and in the dgMarket and UNDB online and may be published in any other manner directed by USFCo or GoP.

54. **Performance Bond**

A USF Service Provider proposed by an Applicant to whom an LOI has been directed shall furnish the Performance Bond in accordance with this RFA Process and the USF Services and Subsidy Agreement. The Performance Bond shall be prepared in the form of Schedule F to the USF Services and Subsidy Agreement, and shall be furnished within ten (10) days of the date of receipt of the LOI.

55. **Information Provided by USFCo**

55.1 The information contained in this RFA and any other information provided to Applicants during the Proposal process is intended to assist Applicants in the preparation of their Proposals. USFCo will ensure that all Applicants are provided with the same information during the Proposal process, in accordance with sections 33.5 and 33.6 of this RFA.

55.2 USFCo has made and will continue to make reasonable efforts to include accurate and current information in this RFA and in any other documentation provided to Applicants and potential Applicants. However, neither USFCo nor any of its agencies, employees, representatives, advisors or consultants shall have any liability whatsoever to any Applicant or any of its shareholders or members or any other Person resulting from use of or reliance on any of the information so provided. Applicants are encouraged to undertake their own verification of any information supplied by USFCo prior to use of or reliance on that information.

56. **Communications, Comments and Requests for Clarification**

56.1 All deliveries, notices or other communications made by USFCo to Applicants in connection with the Proposal process shall be sent by fax, e-mail or personal delivery to the registered office of the Applicant, as specified at the time the Applicant registered with USFCo pursuant to this RFA Process.

56.2 All deliveries, notices or other communications made by Applicants to USFCo in connection with the Proposal process, except for submission of the Proposal itself, shall be sent in writing by e-mail or personal delivery, unless otherwise specified by USFCo, to the contact person and address specified in section 9.1.

56.3 Subject to section 48.1, during the period between the deadline for submissions of Proposals and the award of the USF Subsidy, no

Applicant, no USF Service Provider proposed by an Applicant and no party interested in a Proposal shall be permitted to discuss the merits of any Proposal with any representative of USFCo. Any communications, or attempted communications, in contravention of this section shall be grounds for immediate disqualification.

- 56.4 Applicants are expected to carefully examine all instructions, forms and annexes in this RFA. Failure to furnish all information required by this RFA or the submission of a Proposal that does not comply with the RFA in all respects may result in disqualification of the Proposal.
- 56.5 A prospective Applicant requiring any clarification of this RFA or the draft USF Services and Subsidy Agreement may pose one or more questions to USFCo in writing by e-mail or personal delivery up to twenty one (21) days prior to the closing date for Proposals. USFCo will respond in writing to such written questions following the pre-proposal meeting described in section 33 above. Written questions received by USFCo less than twenty one (21) days prior to the closing date will not be answered.
- 56.6 A prospective Applicant may make comments on the structure and contents of this RFA or the draft USF Services and Subsidy Agreement. Such comments should be sent in writing by e-mail or personal delivery to USFCo up to twenty one (21) days prior to the closing date for Proposals. USFCo will respond in writing to such written comments following the pre-proposal meeting described in section 33 above. USFCo will not respond to written comments received by USFCo less than twenty one (21) days prior to the closing date.
- 56.7 To assist in the examination and evaluation of Proposals, USFCo may, at its discretion, ask any Applicant for a clarification of its Proposal. Any clarification submitted by an Applicant in respect to its Proposal that is not in response to a request by USFCo shall not be considered. USFCo's request for clarification and any response shall be in writing. Subject to sub-section 48.5, no change in the proposed USF Subsidy amount shall be sought, offered or permitted, except to confirm the correction of arithmetic errors discovered by USFCo in the evaluation of the Proposals. In responding to any request for clarification, Applicants may not attempt to change their Proposals, and any response that USFCo determines constitutes a change to an Applicant's Proposal shall not be taken into account by USFCo in evaluating the Proposal.

## 57. **Confidentiality of Proposals**

- 57.1 Except for the public opening of USF Subsidy Proposals pursuant to section 47, USFCo shall treat all Proposals received in relation to this RFA as confidential during the period before the award of the USF Services and Subsidy Agreement.

57.2 USFCo and its agencies, employees, representatives, advisors or consultants shall take reasonable steps to protect Proposal related information from improper use or disclosure; however, liability for disclosure shall be subject to the limitation set out in section 61.3.

57.3 Information relating to the examination, evaluation, comparison, and qualification of Proposals, and any recommendation of Contract award, shall not be disclosed by any representative of USFCo or GoP to Applicants or any other Persons not officially concerned with such process except as specifically permitted by sections 47, 48, and 53.5 of this RFA.

58. **USFCo Use of Proposals**

Subject to compliance with intellectual property laws of Pakistan, and section 57 above, USFCo shall have the right to use or reproduce ideas and information contained in a Proposal without notice or payment of any kind to the Applicant.

59. **Cost of Proposal and Bidding**

The Applicant shall bear all costs associated with the preparation and submission of its Proposal and USFCo will in no case be responsible for any such costs, regardless of the conduct or outcome of the Proposal process.

60. **Reservation of Rights**

60.1 USFCo reserves the right, in its sole discretion, to take any action, including amendment of this RFA, which it considers necessary to ensure that the RFA Process proceeds in a fair, open and transparent manner, in accordance with the laws of Pakistan and to meet the objectives of USFCo.

60.2 USFCo reserves the right to modify or terminate the RFA Process at any time in its sole discretion.

60.3 USFCo is not legally obligated to execute the USF Services and Subsidy Agreement. It may terminate the RFA Process or revoke an award of the USF Services and Subsidy Agreement at any time before the USF Services and Subsidy Agreement is executed.

61. **Legal and Formal Requirements**

61.1 **Governing Law** - This RFA and any USF Services and Subsidy Agreement executed pursuant to this RFA shall be exclusively subject to, and interpreted in accordance with, the laws of Pakistan.

61.2 **Settlement of disputes** - Any dispute, controversy or claim arising out of or in connection with this RFA document, or the breach, termination



or invalidity thereof, shall be subject to the dispute resolution terms and processes set out in Annex 7 to this RFA.

- 61.3 **Limitation of Liability** - Neither GoP nor any of its Ministries, agencies, employees, representatives, advisors or consultants, including USFCo and its officers, employees and contractors, shall incur any liability whatsoever to any Applicant or any USF Service Provider proposed by an Applicant, or any of their respective shareholders or members or any other Person, in connection with any damages, losses, expenses or injury whatsoever, including but not limited to loss of revenue, opportunity, or goodwill, resulting from participation in the RFA Process, including reliance of any person on the information set out in this RFA; it being understood and agreed that USFCo's or GoP's liability for damages shall, in any event, be limited to such amount as may have been actually paid by an Applicant or other person to participate in the RFA Process.
- 61.4 **Language** - The Proposal, the accompanying documents, and all correspondence relating to this RFA shall be submitted in the English language.



## Part IV Definitions

### 62. Definitions

In this Request for Applications (RFA), unless the subject matter or context otherwise requires, the following terms shall have the following meanings:

**“Act”** means the *Pakistan Telecommunication Act (Re-Organization) Act, 1996*, XVII of 1996, as amended, and any successor legislation;

**“Applicant”** means any Person that registers itself with USFCo as an Applicant for purposes of this RFA, having obtained a copy of this RFA from USFCo;

**“Bandwidth”** means the range within a band of frequencies or wavelengths or an amount of data that can be transmitted in a fixed amount of time usually expressed in bits per second (bps) or bytes per second (Bps)

**“Bid Bond”** means the financial security for the bid, including any pay order or demand draft in the name of USFCo, that an Applicant must furnish to USFCo in accordance with section 39 of this RFA;

**“Compliance Checklist”** means the form set out in Annex 5 to this RFA that Applicants must complete in accordance with section 44 of this RFA;

**“Consortium Applicant”** means a group of Persons, including a joint venture, that submits a Proposal on behalf of its members, and that meets all eligibility requirements identified in section 38.1 of this RFA;

**“Contract”** means the USF Services and Subsidy Agreement signed with one or more successful Qualified Applicants on successful conclusion of the RFA Process;

**“Control”** of a Person other than an individual means the ownership of at least 51% (fifty-one percent) of the voting interests in the subject Person; or the possession, directly or indirectly, of the power to direct or cause the direction of the management of that Person, whether through the ownership of shares, voting, securities, partnership or other ownership interests, agreement or otherwise;

**“GoP”** means the Government of Pakistan;

**“Interconnection Regulations”** means any interconnection regulations, rules or guidelines that may be issued by PTA from time to time;

**“Letter of Acceptance”** means the letter described in section 53.3 of this RFA;

**“Letter of Intent”** or **“LOI”** means the letter described in section 53.1 of this RFA;

**“Licence”** means any telecommunications licence granted by the PTA to the USF Service Provider, or to any shareholder of the USF Service Provider that meets the

requirements of section 35.2, which authorizes it to provide the USF Services, as that Licence may be amended;

**“Net worth”** for the purposes of sections 35 means total assets minus total liabilities

**“Optional Services”** means services that a USF Service Provider is authorized but not required to provide pursuant to the USF Services and Subsidy Agreement and any Licences held by a USF Service Provider;

**“Performance Bond”** means the financial security for performance a USF Service Provider must furnish in accordance with section 54 of this RFA;

**“Person”** means any individual, firm, company, corporation, partnership, joint venture or other consortium, government or governmental entity;

**“Point of Interconnection”** or **“POI”** means a connection point between the networks of two telecommunications service providers;

**“Project Implementation Milestones”** means the milestones for the roll-out of the USF Network and provision of the USF Services identified in Schedule D of the USF Services and Subsidy Agreement;

**“Proposal”** means a proposal submitted by an Applicant in response to this RFA;

**“PSTN”** means the public switched telecommunications network of Pakistan;

**“PTA”** means the Pakistan Telecommunication Authority, a statutory body corporate established under Section 3 of the Act, and its predecessors and successors;

**“Qualifications and Service Proposal”** means Part 1 of the Proposal that Applicants must prepare in accordance with section 41.1(a) of this RFA;

**“Qualified Applicant”** has the meaning ascribed thereto in section 34 of this RFA;

**“RFA”** means this Request for Applications, including all annexes hereto, as amended or modified by USFCo;

**“Technical Auditor”** means the Person appointed in accordance with the USF Services and Subsidy Agreement;

**“USF Areas”** mean the Tehsil HQs or towns identified in Schedule C of the USF Services and Subsidy Agreement as being mandatory for USF Network and USF Services;

**“USF Contributor”** means any Person who’s Licence includes identified USF Contribution requirements, and who is identified by PTA as being fully compliant with those requirements;

**“USF Optic Fiber Communication Services”** or **“USF OFC Services”** or **“USF Services”** means transmitting intelligence from one place to another by sending light

through an Optic Fiber for Voice, Data and Video signals through various bandwidth capacities, to be provided by the USF Service Provider pursuant to SSA;

**“USF Optic Fiber Network”** or **“USF OFN”** or **“USF Network”** means the network, that processes and switches signals in or through Optic Fiber Cable and is widely used in Optic Fiber Communication over longer distances and at higher data rates than other forms of communications, to be deployed by the USF Service Provider to provide USF Optic Fiber Communication Services pursuant to the Services and Subsidy Agreement;

**For the purpose of definition:**

- (a) “Network” means a telecommunication system that transmits and electrical, optical or radio signal from one place to another over multiple links and through various nodes; and
- (b) “Optic Fiber” means fiber made of glass or plastic that carries light along its length and includes a cable containing one or more optical fibers, typically individually coated with plastic layers and contained in a protective tube suitable for the environment where the cable will be deployed;

**“USF Rules”** means the Universal Service Fund Rules, 2006 (as amended);

**“USF Service Provider”** means the Person put forward by an Applicant that will provide the USF Services in accordance with the USF Services and Subsidy Agreement;

**“USF Services and Subsidy Agreement”** means the agreement, a draft of which is annexed as Annex 6 to this RFA, for the construction and roll-out of the USF Network, provision of the USF Services and payment of the USF Subsidy to be granted pursuant to this RFA;

**“USF Subsidy”** means the subsidy to be paid by USFCo to the USF Service Provider on the USF Service Provider achieving the Project Implementation Milestones;

**“USF Subsidy Proposal”** means Part 2 of the Proposal that Applicants must prepare in accordance with section 43 of this RFA;

**“USF Subsidy Proposal Form”** means the form attached at Annex 1 of this RFA; and

**“USFCo”** means the Universal Service Fund, a company setup under Section 42 of the Companies Ordinance 1984 and its successors.

**End of Part IV**

## Annex 1: USF Subsidy Proposal Form

### RFA TO PROVIDE USF TELECOMMUNICATIONS SERVICES

To: The Chief Executive Officer  
 USFCo  
**Fifth Floor, HBL Tower, Jinnah Avenue,**  
 Islamabad  
 Pakistan

#### Applicant's USF Subsidy Proposal:

The Applicant, [*insert name of Applicant*], hereby commits to assume all of the USF Service obligations identified in the RFA and USF Services and Subsidy Agreement in consideration for the award of the USF Services and Subsidy Agreement and payment of the amount of USF Subsidy indicated in the following table:

<b>USF Areas:</b>  <i>As identified in Schedule C of USF Services and Subsidy Agreement.</i>	<b>Amount of Proposed USF Subsidy (in Pakistan rupees):</b>  <i>[Enter amount of USF Subsidy proposed for the USF Areas. The amount must be set out in both words and numbers.]</i>
<b>Total cost of the Project</b>	<i>[Enter amount of total cost of Project, proposed for the USF Areas. The amount must be set out in both words and numbers.]</i>

1. In the event of any discrepancy between the USF Subsidy amount and total cost of the Project set out in words and numbers, the amount set out in words shall govern.
2. This USF Subsidy Proposal shall remain valid in accordance with section 50 of the RFA.

Signature: \_\_\_\_\_ Print Name: \_\_\_\_\_

in the capacity of [*insert title/position of individual signing*] duly authorized to sign for and on behalf of [*insert name of Applicant*].

Dated this \_\_\_\_\_ day of \_\_\_\_\_, 20XX.

Witness Signature: \_\_\_\_\_ Print Name: \_\_\_\_\_

Dated this \_\_\_\_\_ day of \_\_\_\_\_, 20XX.

## Annex 2: Bid Bond Form

To: The Chief Executive Officer  
USFCo  
**Fifth Floor, HBL Tower, Jinnah Avenue,**  
Islamabad  
Pakistan

WHEREAS the Universal Service Fund, hereinafter called the “USFCo”, has issued the Request for Applications to Provide Universal Service Fund (USF) Telecommunications Services, hereinafter called the “RFA”, dated [*insert date*];

AND WHEREAS the Universal Service Fund Telecommunications Services, hereinafter called the “SERVICES”, shall be provided in accordance with a service agreement, hereinafter called the “AGREEMENT”, to be executed in accordance with the RFA, and any licence, hereinafter called the “LICENCE”, issued by the PTA that authorizes provision of the SERVICES;

AND WHEREAS [*insert name of Applicant*], hereinafter called the “APPLICANT”, is submitting a proposal, hereinafter called the “PROPOSAL”, dated [*insert date of Proposal*] to provide the “SERVICES”;

KNOW ALL PEOPLE by these presents that we [*insert name of bank*] having our registered office at [*insert address of bank*], hereinafter called the “BANK”, are bound unto the USFCo by the amount of PKR [1,500,000] willingly and truly to be paid out to the said USFCo upon entering any of the conditions specified below. The BANK binds itself, its successors and assigns by these presents sealed with the common seal of the BANK this [*insert day*] day of [*insert month*], 2009.

The conditions of this obligation are:

1. If the APPLICANT withdraws its PROPOSAL prior to execution of the AGREEMENT;
2. If the APPLICANT, having been notified of the acceptance of the PROPOSAL by the USFCo during the period of validity of the PROPOSAL, fails or refuses to furnish the Performance Bond of the specified amount and correct validity and the Letter of Acceptance in accordance with the instructions given in the Letter of Intent issued by the USFCo;
3. If after the issuance of the Letter of Intent the USFCo determines that APPLICANT is disqualified pursuant to section 51.1 of the RFA; or
4. The APPLICANT does not execute the AGREEMENT within any identified time period after completing final AGREEMENT negotiations.

We undertake to pay to the USFCo up to the above amount upon receipt of its first written demand without the USFCo having to substantiate its demand, provided that in its demand the USFCo will note that the amount claimed by it is due to the occurrence of one or more of the aforementioned conditions, specifying the condition or conditions that have occurred.

This guarantee will remain valid for 210 days from the closing date of submission of the PROPOSAL (i.e. until [*insert expiry date*]) and any demand in respect thereof should reach the BANK not later than the above date.

Signature and Seal of BANK:

Date:

**Annex 3: World Bank Eligibility Guidelines**  
**(Will only be applicable if funding is from World Bank)**

Note: The text in this Annex is an extract of the procurement section of the following URL:

<http://web.worldbank.org/WBSITE/EXTERNAL/PROJECTS/PROCUREMENT/0,,pagePK:84271~theSitePK:84266,00.html>

**Eligibility for the Provision of Goods, Works and Services in Projects Financed by the World Bank**

**Current Policy**

In November 2003, the World Bank approved revisions to the Guidelines: Procurement under IBRD Loans and IDA Credits and Guidelines: Selection and Employment of Consultants by World Bank Borrowers. These guidelines, which became effective in May 2004 do not contain procurement restrictions based on nationality. As stated in paragraph 1.6 of the Guidelines, **persons or entities from any country are eligible to participate in Bank-financed procurement for all loans or credits for which the invitation to negotiate was issued after May 1, 2004.**

Exceptions to this are noted in paragraph 1.8 of the procurement guidelines.

According to these exceptions, persons or entities of a Country, or goods and services that have their origin in a Country may be excluded if:

Para 1.8 (a) (i): as a matter of law or official regulation, the Borrower's Country prohibits commercial relations with that Country, provided that the Bank is satisfied that such exclusion does not preclude effective competition for the supply of the Goods or Works required; or

Para 1.8 (a) (ii): by an Act of Compliance with a Decision of the United Nations Security Council taken under Chapter VII of the Charter of the United Nations, the Borrower's Country prohibits any import of goods from that Country or any payments to persons or entities in that Country.

**Additional Requirements**

The Contractor and its sub-contractors shall have the nationality of an eligible country. It is considered that a Contractor or sub-contractor has the nationality of a country if he is a citizen or



is constituted, incorporated or registered and operates in accordance with the rules and laws of this country.

All goods and services to be provided under the Contract and financed by the Bank shall have their origin in eligible countries. For the purposes of this clause, “origin” means the country where the goods were extracted, harvested, cultivated, produced, made, manufactured or processed, or, when affected by processing, manufacturing or mounting, become a new item commercially recognized as differing substantially from the basic features of its components.

The origin of goods and services is distinct from the nationality of a bidder or Contractor.

**Annex 4: Form of Letter Regarding Compliance with Licence(s)**

[*Month*] [*Day*], 20XX

The Chief Executive Officer  
USFCo  
**Fifth Floor, HBL Tower, Jinnah Avenue,**  
Islamabad  
Pakistan

Dear Sir:

**Re:** [*insert name of proposed USF Service Provider or Person falling within one of the categories listed in section 36.2(b) of the RFA*]

**Compliance with Conditions of Telecommunications Licence(s)**

[*insert name of proposed USF Service Provider or Person falling within one of the categories listed in section 36.2(b) of the RFA*] is the holder of the following telecommunications licences issued by the PTA:

[*list all PTA issued licences, including appropriate licence identification and date*]

[*insert name of proposed USF Service Provider or Person falling within one of the categories listed in section 36.2(b) of the RFA*] remains in substantial compliance with all terms and conditions of the licence(s) issued by the PTA, and otherwise remains in good standing with the PTA.

Yours very truly,

***[insert name of proposed USF Service Provider or Person falling within one of the categories listed in section 36.2(b) of the RFA]***

Per:

---

**(Signature)**

***[insert name and title of person signing letter]***

***[insert phone number of person signing letter]***

***[insert postal and e-mail address of person signing letter]***

**cc: Director General (Licensing), Pakistan Telecommunication Authority**

### Annex 5: Compliance Checklist

#### 1. Compliance Sheet

A complete compliance sheet for each clause / sub-clause of RFA / SSA / Annexure / Schedules shall be provided as softcopy and as signed hardcopy in the following format

Document	Clause No.	Compliance (FC/PC/NC/NA)	Proposal Page Reference	Remarks in case of Partially or Not Complied
RFA				
SSA				
Schedules				
Annexes				

Note: FC- Fully Complied, PC – Partially Complied, NC – Not Complied, NA – Not Applicable.

#### 2. Design Parameters

Following table of design parameters shall be filled up for the proposed solution

ITEM		VALUE
Vendor		
Tehsils Covered		
THQ's Covered		
Towns Covered		
Route Length (Kms)		
Type & No. of Nodes	ADM STM-16	
	TM STM-16	
	ADM STM-4	
	TM STM-4	
	ADM STM-1	
	TM STM-1	

	Regenerator	
Fiber Type (Standard)		
Cable Type and No. of Pairs		
Mode Field diameter of Fiber Optic Cable		
Mode Field Concentricity Error		
Cladding Diameter of Fiber Optic Cable		
Cladding non circularity		
Cladding Concentricity Error		
Wavelength of Light		
Average Attenuation for Fiber Optic Cable (dB/km) at 1310 nm and 1550 nm		
PMD (Maximum for each individual fiber) (ps/ $\sqrt{\text{km}}$ )		
Fiber Optic cable cutoff wavelength		
Chromatic Dispersion		
Optical Safety		
Supporting Colored Wavelength		
Protection and Reliability		
Cross Connect capabilities		
Ethernet facilities		
Synchronization capabilities		
NMS capacity		
NMS Software Platform		
NMS Response Time		
Depth of laid cable		
Use of Bricks / Ducts		

### 3. Additional Information

- a) GIS information (Mapinfo work-package) of the planned routes (compatible with Mapinfo version 9.5) shall be provided including following information;
  - i) Location of the nodes with names
  - ii) OFC routes with distance
- b) Cable route & network connectivity diagrams (compatible with MS Visio) shall be provided including following information;
  - i) Nodes with names, capacity, ownership (USF or SP existing/planned etc)
  - ii) Links with distances, number of pairs & type, ownership (USF or SP existing/planned)

**Annex [6]**

**Draft of Proposed USF Services and Subsidy Agreement**

**UNIVERSAL SERVICE FUND  
SERVICES and SUBSIDY AGREEMENT**

---

**BETWEEN**

**UNIVERSAL SERVICE FUND  
(A company setup under Section 42 of the Companies Ordinance 1984)**

**AND  
[•]**

**MADE AS OF  
[•MONTH•] [•DAY•], 20XX**

---

**TABLE OF CONTENTS**

ARTICLE ONE - INTERPRETATION ..... - 1 -

    1.01 Definitions..... - 1 -

    1.02 Headings ..... - 5 -

    1.03 Extended Meanings..... - 5 -

    1.04 Currency..... - 5 -

    1.05 Schedules ..... - 5 -

ARTICLE TWO - PROVISION OF USF NETWORK AND USF SERVICES ..... - 5 -

    2.01 General..... - 5 -

    2.02 Implementation of the USF Network..... - 6 -

    2.03 Provision of USF Services ..... - 6 -

    2.04 Service Availability and Quality..... - 6 -

    2.05 Facilities Access and Sharing ..... - 6 -

    2.06 USF Service Charges ..... - 7 -

ARTICLE THREE - OWNERSHIP AND CONTROL ..... - 7 -

    3.01 Ownership and Operation of USF Network..... - 7 -

    3.02 Change of Control of USF Service Provider ..... - 7 -

ARTICLE FOUR - IMPLEMENTATION AND SERVICE FAILURES ..... - 8 -

    4.01 Failure to Meet Project Implementation Milestone Schedule..... - 8 -

    4.02 Failure to Maintain Service Availability and Quality Specifications ..... - 8 -

    4.03 Additional Penalties or Remedies ..... - 9 -

ARTICLE FIVE - PAYMENT OF THE USF SUBSIDY..... - 9 -

    5.01 Payment of USF Subsidy ..... - 9 -

ARTICLE SIX - PERFORMANCE SECURITY ..... - 9 -

    6.01 Performance Bond ..... - 9 -

    6.02 Equipment Lien..... - 10 -

ARTICLE SEVEN - INSURANCE ..... - 10 -

    7.01 Insurance..... - 10 -

    7.02 General..... - 11 -

    7.03 Changes in the Insurance Industry ..... - 11 -

ARTICLE EIGHT - TECHNICAL AUDITOR..... - 11 -

    8.01 Appointment of Technical Auditor..... - 11 -

    8.02 Role of Technical Auditor ..... - 12 -

8.03 Cooperation with Technical Auditor ..... - 13 -

ARTICLE NINE - REPORTING ..... - 13 -

9.01 Reports ..... - 13 -

ARTICLE TEN - DISPUTE RESOLUTION ..... - 14 -

10.01 Dispute Escalation Process ..... - 14 -

10.02 Referral to Appeal Committee ..... - 16 -

10.03 Arbitration or Court Proceedings ..... - 16 -

10.04 Dispute Resolution Costs ..... - 16 -

10.05 Exemption from Dispute Resolution Processes ..... - 16 -

ARTICLE ELEVEN - REPRESENTATIONS AND WARRANTIES ..... - 17 -

11.01 Mutual Representations and Warranties ..... - 17 -

11.02 Representations and Warranties of USF Service Provider ..... - 17 -

ARTICLE TWELVE - INDEMNIFICATION ..... - 18 -

12.01 Indemnification ..... - 18 -

ARTICLE THIRTEEN - FORCE MAJEURE ..... - 18 -

13.01 Force Majeure ..... - 18 -

13.02 Technical Amendments ..... - 20 -

13.03 No Payment for Unperformed Services ..... - 21 -

13.04 Duration of Force Majeure Event Beyond Six Months ..... - 21 -

ARTICLE FOURTEEN - CONFIDENTIALITY ..... - 22 -

14.01 Confidentiality ..... - 22 -

ARTICLE FIFTEEN - TERM AND TERMINATION ..... - 22 -

15.01 Term ..... - 22 -

15.02 Termination – Bankruptcy, Winding Up, Etc. .... - 22 -

15.03 Termination – Material Breach ..... - 23 -

15.04 Termination – Remedies ..... - 23 -

ARTICLE SIXTEEN - GENERAL ..... - 23 -

16.01 Records, Audit and Inspection ..... - 23 -

16.02 Time of the Essence ..... - 24 -

16.03 Expenses ..... - 24 -

16.04 Public Announcements ..... - 24 -

16.05 Benefit of the Agreement ..... - 24 -

16.06 Entire Agreement ..... - 24 -



16.07	Severability .....	- 24 -
16.08	Amendments and Waiver.....	- 24 -
16.09	Assignment .....	- 25 -
16.10	Subcontractors and Other Suppliers.....	- 25 -
16.11	Notices .....	- 25 -
16.12	Governing Law .....	- 25 -
ARTICLE SEVENTEEN - COMPLIANCE WITH ENVIRONMENTAL LAWS.....		- 26 -
17.01.....		- 26 -
<p>Schedule A – (Part – I) Optic Fiber Connectivity with un-served Tehsil HQ, Availability, &amp; Quality Specifications                      (Part – II) Technical Specifications</p> <p>Schedule B – Proposed Traffic Matrix (Bandwidth Capacities) for each O.F. Link included in Schedule C, Availability &amp; Quality Specifications</p> <p>Schedule C – USF Areas</p> <p>Schedule D – USF Project Implementation and Subsidy Payment Schedule</p> <p>Schedule E – Material Events of Default</p> <p>Schedule F – Performance Bond</p> <p>Schedule G – Letter of Lien</p> <p>Schedule H – Service Provider’s Technical Proposal</p> <p>Schedule I – Service Provider’s Financial Proposal</p> <p>Schedule J – Bid Clarifications</p>		

## **UNIVERSAL SERVICE FUND SERVICES AND SUBSIDY AGREEMENT**

THIS AGREEMENT is made as of [●Month●] [●Day●], 20XX;

B E T W E E N:

USF, a company setup under the Companies Ordinance 1984 having its principal office at Fifth Floor, HBL Tower, Jinnah Avenue, Islamabad through its Chief Executive Officer, (hereinafter referred to as “USFCo”)

- and -

[●]

(hereinafter referred to as “USF Service Provider”).

WITNESSES THAT:

WHEREAS USFCo wishes to ensure the supply of certain USF Services to certain unserved and under-served areas and to facilitate the implementation of a USF Network to provide such services;

AND WHEREAS the USF Service Provider has been selected by USFCo through competitive process to construct the USF Network and provide the USF Services in certain unserved and under-served areas;

AND WHEREAS the USF Service Provider wishes to construct the USF Network and to provide USF Services upon and subject to the terms and conditions hereinafter set forth;

NOW THEREFORE, the parties hereto agree as follows:

### **ARTICLE ONE - INTERPRETATION**

#### **1.01 Definitions**

In this Agreement, unless something in the subject matter or context is inconsistent therewith:

“**Act**” means the *Pakistan Telecommunication Act (Re-Organization) Act, 1996* (XVII of 1996) as may be amended, and any successor legislation;

“**Bandwidth**” means the range within a band of frequencies or wavelengths or an amount of data that can be transmitted in a fixed amount of time usually expressed in bits per second (bps) or bytes per second.

“**Business Day**” means a day other than a Saturday, Sunday or statutory holiday in Pakistan;

**“Companies Ordinance”** means the *Companies Ordinance, 1984* as may be amended, or any successor legislation;

**“Constating Instruments”** includes any certificate of incorporation, certificate of continuance, memorandum and articles of association, by-laws, regulations or other instrument by which a body corporate is incorporated or continued under the Companies Ordinance or that governs or regulates the affairs of a body corporate;

**“Control”** of a Person that is not an individual means the ownership of at least 51% (fifty-one percent) of the voting interests in the subject Person; or the possession, directly or indirectly, of the power to direct or cause the direction of the management of that Person, whether through the ownership of shares, voting, securities, partnership or other ownership interests, agreement or otherwise;

**“Customer Service Agreement”** has the meaning ascribed thereto in Section 2.03(d);

**“Effective Date”** means the effective date of this Agreement, as recorded on the first page hereof;

**“Final Implementation Date”** means the date identified in paragraph 3 of Schedule D;

**“Force Majeure Certification”** has the meaning ascribed thereto in Section 13.01(c)(i);

**“Force Majeure Event”** has the meaning ascribed thereto in Section 13.01(h);

**“Force Majeure Notice”** has the meaning ascribed thereto in Section 13.01(a);

**“GoP”** means the Government of Pakistan;

**“Indemnification Notice”** has the meaning ascribed thereto in Section 12.01(b);

**“Licence”** means any telecommunications licence granted by the PTA to the USF Service Provider, prior to the Effective Date, which authorizes it to provide the USF Services;

**“Optional USF Services”** means services that the USF Service Provider is authorized but not required to provide pursuant to this Agreement and any Licence;

**“Parties”** means USFCo and the USF Service Provider, and **“Party”** means any one of them;

**“Performance Bond”** has the meaning ascribed thereto in Section 6.01;

**“Person”** means any individual, firm, company, corporation, partnership, joint venture or other consortium, government or governmental entity;

**“Project Implementation Milestones”** means the milestones for the roll-out of the USF Network and provision of the USF Services, and related schedule for payment of the USF Subsidy, set out in Schedule D;

**“Project Implementation Milestone Certification”** has the meaning ascribed thereto in Schedule D;

**“Project Implementation Milestone Notice”** has the meaning ascribed thereto in Schedule D;

**“Proposal”** means the proposal submitted by the USF Service Provider, or the company or joint venture that incorporated the USF Service Provider, in response to the RFA;

**“PTA”** means the Pakistan Telecommunication Authority, a statutory body corporate established under section 3 of the Act, and its predecessors and successors;

**“Relationship Executive Committee”** has the meaning ascribed thereto in Section 10.01(d)(i);

**“Relationship Liaison Committee”** has the meaning ascribed thereto in Section 10.01(c)(i);

**“Relationship Manager”** has the meaning ascribed thereto in Section 10.01(b)(i);

**“RFA”** means the Request for Applications document issued by USFCo on 19<sup>th</sup> April 2013, including all annexes thereto, as amended or modified by USFCo;

**“Report”** means a Report required in accordance with Section 9.01;

**“Technical Amendment”** has the meaning ascribed thereto in Section 13.02(a);

**“Technical Auditor”** means the person appointed in accordance with Section 8.01(a);

**“Term”** means the term of the Agreement identified in Section 15.01;

**“USF Areas”** means the Tehsils or towns identified in Schedule C as being mandatory for USF Network and USF Services;

**“USFCo”** means the Universal Service Fund, a company setup under Section 42 of the Companies Ordinance 1984 and its successors;

**“USF Contributor”** means any Person whose License includes identified USF Contribution requirements, and who is identified by PTA as being fully compliant with those requirements;

**“USF Fiber Optic Communication Services”** or **“USF FOC Services”** means transmitting intelligence from one place to another by sending light through an fiber Optic for Voice ,Data and Video signals through various bandwidth capacities , to be provided by the USF Service Provider pursuant to this Agreement

**“USF Fiber Optic Network”** or **“USF FON”** means the network, that processes and switches signals in or through Fiber Optic and is widely used in Fiber Optic Communication over longer distances and at higher data rates than other forms of

communications, to be deployed by the USF Service Provider to provide USF Fiber Optic Communication Services pursuant to this Agreement;

**“USF Rules”** means the Universal Service Fund Rules, 2006 (as amended);

**“USF Services and Subsidy Agreement”** or **“Agreement”** means this agreement and all amendments made hereto by written agreement between the parties;

**“USF Service Provider”** means the Party, other than USFCo, identified on the first page of this Agreement (referred to as the “Contractor” in the USF Rules);

**“USF Services”** means the Telephony Services and the Internet Access Services; and

**“USF Subsidy”** means the subsidy to be paid by USFCo to the USF Service Provider on the USF Service Provider achieving the Project Implementation Milestones.

## 1.02 **Headings**

The division of this Agreement into Articles and Sections and the insertion of a table of contents and headings are for convenience of reference only and do not affect the construction or interpretation of this Agreement. The terms “hereof”, “hereunder” and similar expressions refer to this Agreement and not to any particular Article, Section or other portion hereof. Unless something in the subject matter or context is inconsistent therewith, references herein to Articles, Sections and Schedules are to Articles and Sections of and Schedules to this Agreement.

## 1.03 **Extended Meanings**

In this Agreement words importing the singular number only include the plural and *vice versa*, words importing any gender include all genders.

## 1.04 **Currency**

All references to currency herein are to Pakistan rupees (PKR), unless stated otherwise in this Agreement.

## 1.05 **Schedules**

The following are the Schedules annexed hereto and incorporated by reference and deemed to be part hereof:

- Schedule A – (Part – I) Optic Fiber Connectivity with un-served Tehsil HQ, Availability, & Quality Specifications  
(Part – II) Technical Specifications
- Schedule B – Proposed Traffic Matrix (Bandwidth Capacities) for each O.F. Link included in Schedule C, Availability & Quality Specifications
- Schedule C – USF Areas
- Schedule D – USF Project Implementation and Subsidy Payment Schedule
- Schedule E – Material Events of Default
- Schedule F – Performance Bond
- Schedule G – Letter of Lien
- Schedule H – Service Provider’s Technical Proposal
- Schedule I – Service Provider’s Financial Proposal
- Schedule J – Bid Clarifications

## **ARTICLE TWO - PROVISION OF USF NETWORK AND USF SERVICES**

### 2.01 **General**

Subject to the provisions of this Agreement, the USF Service Provider will construct the USF Network and provide the USF Services, and USFCo will provide the USF Subsidy to assist in meeting the costs of constructing the USF network for providing the USF Services in the USF Areas.

## 2.02 **Implementation of the USF Network**

- (a) The USF Service Provider shall implement the USF Network in accordance with the Project Implementation Milestones, and Final Implementation Date, identified in Schedule D.
- (b) In implementing the USF Network, the USF Service Provider shall comply with all planning and approvals processes, and applicable environmental guidelines.

## 2.03 **Provision of USF Services**

- (a) The USF Service Provider shall provide the USF Services in accordance with the service specifications and requirements identified in Schedules A and B.
- (b) The USF Service Provider shall provide the USF Services in the USF Areas identified in Schedule C as being mandatory for USF Network and USF Service coverage in accordance with the network and service roll-out requirements identified in Schedule D.
- (c) In addition to the USF Services, the USF Service Provider may provide any other services authorized by the Licence or another PTA-issued licence held by the USF Service Provider in Pakistan.
- (d) The USF Services shall be provided by the USF Service Provider pursuant to an agreement with wholesale or retail customers of the USF Services. The Customer Service Agreement, lease agreement or interconnection agreement shall be in a form approved by the PTA.
- (e) The successful Applicant will connect through USF Network the un-served Tehsil Headquarters from the nearest city or town having optic fiber connectivity. He may co-locate his equipment with the existing Operator or may consider connecting to its own nearest node.

## 2.04 **Service Availability and Quality**

The USF Service Provider shall provide the USF Services in accordance with the quality of service requirements identified in Schedules A and B, any quality of service requirements identified in the USF Service Provider's Licence and any quality of service regulations issued by PTA.

## 2.05 **Facilities Access and Sharing**

- (a) As required pursuant to Rule 27 of the USF Rules, the USF Service Provider shall share the USF Network, infrastructure and facilities (i.e., dark fiber, buildings, power etc.) with at least one requesting USF contributor, on a first come first served basis and at cost based rates and at rates based on reasonable cost.
- (b) Where the USF Service Provider and USF contributor requesting facilities access and sharing are not able to successfully negotiate the terms of access, following a

reasonable period of good faith negotiation, either party may request the assistance of the PTA in resolving the disputed terms.

- (c) In determining whether rates for infrastructure sharing are based on reasonable cost, or to assist in resolving any other dispute regarding the terms of facilities access, USFCo shall be entitled to disclose information obtained by it pursuant to Section 16.01 to the PTA.
- (d) The USF Service Provider shall also comply with any facilities sharing requirements set out in regulations, guidelines, decisions or orders issued by the PTA.

## 2.06 **USF Service Charges**

- (a) The USF Service Provider's charges for the USF Services shall not exceed the USF Service Provider's National or Regional tariffs for the same or equivalent services provided in other locations that are not included in the USF Areas. To determine compliance with this Section 2.06, reference shall be made to the PTA's then-current records of USF Service Provider tariffs.

## **ARTICLE THREE - OWNERSHIP AND CONTROL**

### 3.01 **Ownership and Operation of USF Network**

- (a) The USF Services shall be provided primarily over network transmission and facilities (i.e. wires, fibre optic lines, cables, etc.) owned and operated by the USF Service Provider.
- (b) The USF Service Provider may extend the reach or capability of its USF Network by acquiring facilities or services from another network operator on a resale basis, that is by transmission over the networks of other operators or by means of leased line services acquired from other telecommunications operators.
- (c) Regardless of whether the USF Services are provided in accordance with Sections 3.01(a) or (b), the obligations hereunder to implement the USF Network and to provide the USF Services remain entirely those of the USF Service Provider.

### 3.02 **Change of Control of USF Service Provider**

For so long as the Performance Bond provided by the USF Service Provider pursuant to Section 6.01 remains in place, the prior written consent of USFCo will be required for any change of Control of the USF Service Provider.



**ARTICLE FOUR - IMPLEMENTATION AND SERVICE FAILURES****4.01 Failure to Meet Project Implementation Milestone Schedule**

- (a) Unless a Force Majeure Certification has been issued to certify that a Force Majeure Event has caused the failure, then failure to meet the Final Implementation Date identified in Schedule D may, at the sole discretion of USFCo, result in the imposition of one or more of the penalties set out below:
- (i) loss of eligibility for all or part of the USF Subsidy;
  - (ii) forfeiture of all or part of the Performance Bond;
  - (iii) payment of liquidated damages equal to one-half of one percent (0.5%) of the USF Subsidy amount payable for the work that is delayed, and such half percent shall be payable per every week the failure continues;
  - (iv) repayment of any USF Subsidy amounts previously paid to the USF Service Provider;
  - (v) payment of liquidated damages equal to all or part of USFCo's estimate of the costs of providing the USF Services in the USF Areas left unserved due to the failure, provided that the total amount of such liquidated damages shall not exceed the amount of the USF Subsidy payable to the USF Service Provider for the provision of the USF Services in the USF Areas.
- (b) Such penalty or penalties shall be specified in a written notice delivered by USFCo to the USF Service Provider in accordance with Section 16.11. The penalty or penalties shall become effective in the manner specified in such notice.

**4.02 Failure to Maintain Service Availability and Quality Specifications**

- (a) Unless a Force Majeure Certification has been issued to certify that a Force Majeure Event has caused the failure, then failure of the USF Service Provider to maintain the Service Availability and Quality Specifications for the USF Services as set out in Schedule A or B may, at the sole discretion of USFCo, result in the imposition of one or more of the penalties set out below:
- (i) loss of eligibility for all or part of the USF Subsidy;
  - (ii) forfeiture of all or part of the Performance Bond;
  - (iii) repayment of any USF Subsidy amounts previously paid to the USF Service Provider;
  - (iv) taking possession of USF Network equipment and the exercise of any other remedies or rights by USFCo under the equipment lien created pursuant to Section 6.02.

- (b) Such penalty or penalties shall be specified in a written notice delivered by USFCo to the USF Service Provider in accordance with Section 16.11. The penalty or penalties shall become effective in the manner specified in such notice.

#### 4.03 **Additional Penalties or Remedies**

The penalties described in Sections 4.01 and 4.02 are in addition to any other penalties or remedies that may otherwise be available to USFCo under this Agreement or the laws of Pakistan.

### **ARTICLE FIVE - PAYMENT OF THE USF SUBSIDY**

#### 5.01 **Payment of USF Subsidy**

USFCo shall pay the USF Service Provider the USF Subsidy in accordance with the subsidy instalment payments identified in Schedule D.

### **ARTICLE SIX - PERFORMANCE SECURITY**

#### 6.01 **Performance Bond**

- (a) The USF Service Provider shall furnish USFCo with an irrevocable bank guarantee in the form specified in Schedule F / F (1), or other form of performance guarantee acceptable to USFCo (the “Performance Bond”).
- (b) The maximum amount of the Performance Bond shall be 40% of the USF Subsidy to the USF service provider. The validity of the Performance Bond will be 5 years, however the USF Service Provider shall have the option to submit a single Performance Bond valid for 5 years or successive five annual Performance Bonds with minimum one year validity in accordance with Schedule “F” or F/1. In case USF Service Provider opts for successive five annual Performance Bonds option then it shall :
1. submit first Performance Bond as per requirements of this RFA with validity of one year;
  2. submit second Performance Bond of same value with minimum one year validity, one month before the expiry date of the first Performance Bond. Similarly it shall submit third, fourth and fifth performance bond annually, provided that the expiry date of the fifth performance Bond shall be the same as the expiry date of the 5 year Performance Bond would have been;
  3. be entitled, after submitting the new Performance Bond, to get released previous Performance Bond from USFCo within 05 days of the effective date of the new Performance Bond ;

4. not have the right to expect or demand a reminder from USFCo regarding expiry of any of the Performance Bonds or submission of new Performance Bond; and
  5. not object to encashment of Performance Bond by USFCo in its custody because of late or non-submission of new Performance Bond..
- (c) The Performance Bond shall be issued by a commercial bank recognised by State Bank of Pakistan, having a branch office in Pakistan, and that is otherwise acceptable to USFCo.
- (d) The Performance Bond shall be maintained for the period identified in Schedule F or in F (1), commencing from the Effective Date.
- (e) The Performance Bond shall be forfeited, in whole or in part, by the USF Service Provider as provided for in Article Four.

#### 6.02 **Equipment Lien**

As required pursuant to Rule 26(6) of the USF Rules, all equipment deployed by the USF Service Provider in implementing the USF Network shall be subject to a lien exercisable by USFCo pursuant to the documented terms of the lien and Section 4.02 (a) (iv). The equipment lien shall have a maximum value equal to the total value of the USF Subsidy. The USF Service Provider shall execute a Letter of Lien (Schedule G) to substantiate the lien or to support its enforceability.

### **ARTICLE SEVEN - INSURANCE**

#### 7.01 **Insurance**

The USF Service Provider shall maintain or cause to be maintained on behalf of itself and all subcontractors to whom the USF Service Provider has subcontracted (in relation to the implementation or operation of the USF Network or provision of the USF Services) at all times during the Term of this Agreement, in a form and with insurers acceptable to USFCo, the following types of insurance:

- (a) **Commercial General Liability Insurance** – Commercial general liability insurance covering liability imposed by law or assumed under contract arising from bodily injury, death or property damage including loss of use, with minimum combined limits of not less than PKR 50,000,000/- [Rupees Fifty Million only] per occurrence. Such policy or policies shall be on an occurrence basis and shall provide coverage for full legal defence costs, premises and operational liability, and blanket broad form contractual liability and property damage coverage (including malicious property damage). The policy or policies shall name USFCo as additional insured.
- (b) **Property Insurance** – Property insurance covering property and assets used to operate the USF Network and provide the USF Services on a blanket form basis for all risks of physical loss or damage, with minimum limits equal to the full

replacement cost value of the property. The basis of loss settlement shall be replacement cost with like kind and quality.

## 7.02 **General**

- (a) All insurance provided for in Section 7.01 shall be effected with valid and enforceable policies issued by insurance companies that are licensed to do business in Pakistan.
- (b) All policies shall be endorsed to contain an agreement by the insurer that the coverage will not be cancelled or materially changed to the detriment of USFCo, without at least 30 days' prior written notice to USFCo.
- (c) Within 30 days of the Effective Date, the USF Service Provider shall have the insurance specified herein in full force and effect and shall provide USFCo with certificates of insurance as evidence of such insurance in such form and scope acceptable to USFCo. Such proof of insurance shall be updated to maintain its accuracy, within 14 days of any change in coverage. The USF Service Provider shall notify USFCo promptly and in writing in the event of any termination, expiry, lapse or change in insurance coverage.
- (d) The insurance requirements herein do not limit or modify any liability that would otherwise exist or create any liability that would otherwise not exist under this Agreement in the absence of such insurance requirements.

## 7.03 **Changes in the Insurance Industry**

The Parties agree that should any change in the insurance industry materially impact the USF Service Provider's ability to obtain the insurance and insurance coverage levels set forth in this Article Seven, the Parties will assess such impact and, if deemed necessary by the Parties, negotiate in good faith any amendments to this Article Seven to account for such insurance industry changes, provided however, that nothing herein shall require USFCo to approve of any such amendment.

## **ARTICLE EIGHT - TECHNICAL AUDITOR**

### 8.01 **Appointment of Technical Auditor**

- (a) Within 90 days following the Effective Date, USFCo shall appoint a person as the "Technical Auditor" under this Agreement.
- (b) The Technical Auditor may be an external consultant who shall be a person of demonstrated telecommunications engineering expertise.
- (c) Where the Technical Auditor is an external consultant, USFCo shall enter into an agreement (the "Technical Auditor Agreement") with the Technical Auditor. The Technical Auditor Agreement shall:

- (i) define the role of the Technical Auditor in accordance with this Agreement;
- (ii) prescribe the methodology, tests and reporting structure to be used by the Technical Auditor in performing his or her role;
- (iii) set out the fees to be payable, and expenses to be reimbursable, to the Technical Auditor; and
- (iv) contain any other provisions that USFCo determines necessary to give effect to the appointment and for the performance of the functions of the Technical Auditor identified in this Agreement.

Once executed, USFCo shall make a copy of the Technical Auditor Agreement available to the USF Service Provider.

- (d) USFCo shall be solely responsible for the selection of Technical Auditor and for any fees to be payable, and expenses to be reimbursable, to the Technical Auditor.
- (e) If the Technical Auditor resigns or otherwise ceases to perform the intended functions before the end of this Agreement, or if USFCo decides to replace the Technical Auditor at any time, USFCo shall appoint a replacement Technical Auditor who, for all purposes of this Agreement, shall from and after such appointment perform the functions of the Technical Auditor.
- (f) If the Technical Auditor has been replaced during the execution of the project USFCo will inform the USF Service Provider about this change.

## 8.02 **Role of Technical Auditor**

The Technical Auditor shall perform the following functions, in accordance with this Agreement and the Technical Auditor Agreement:

- (a) making a determination as to whether or not any of the USF Network Project Implementation Milestones identified in Schedule D have been met, which may include, but is not limited to, one or more of the following:
  - (i) making a determination as to whether or not the USF Services meet the service specifications and requirements identified in Schedules A and B;
  - (ii) issuing a Project Implementation Milestone Certification to the Parties to indicate that a Project Implementation Milestone has been completed in accordance with Schedule D; and
  - (iii) issuing an indication in writing to the Parties that a Project Implementation Milestone has not been completed in accordance with Schedule D; and

- (b) making a determination as to whether or not a Force Majeure Event exists in accordance with Article Thirteen, which may include, but is not limited to, one or more of the following:
  - (i) issuing a Force Majeure Certification in accordance with Article Thirteen;
  - (ii) issuing an indication in writing to the Parties that a Force Majeure Event has not occurred in accordance with Article Thirteen; and
  - (iii) proposing a Technical Amendment made in accordance with Article Thirteen.

### 8.03 **Cooperation with Technical Auditor**

The USF Service Provider shall co-operate with the Technical Auditor, in performing his or her functions pursuant to this Agreement and the Technical Auditor Agreement, including by:

- (a) providing access to all USF Network facilities and systems, including for equipment testing purposes, statistical data collection, reporting etc; and
- (b) providing any information regarding the USF Network or the USF Services requested by the Technical Auditor, and related access to technical personnel of the USF Service Provider.

## **ARTICLE NINE - REPORTING**

### 9.01 **Reports**

- (a) The USF Service Provider shall provide to USFCo, within 60 days of the Effective Date and for each calendar quarter (three months) thereafter throughout the Term of this Agreement, a report (the “Report”), which shall include:
  - (i) a detailed USF Network implementation plan and network description;
  - (ii) detailed report on the achievement of the Project Implementation Milestones set out in Schedule D, which should also highlight the risks and bottlenecks during the implementation phase with their proposed measures and the forecasted project progress against the milestones set out in Schedule D;
  - (iii) a report on the achievement of the quality of service and other service requirements for the USF Services set out in Schedules A and B, including details regarding service maintenance and the time required to repair service outages;
  - (iv) a report on general demand for and usage of the USF Services, and the USF Service Provider’s current charges for the USF Services;

- (v) a report on demand for the USF Network and USF Services, indicating:
  - (I) technical capacity and readiness of the USF Network to provide the Services;
  - (II) the USF Service Provider's marketing and distribution plan for the USF Services;
  - (III) the number of requests received by the USF Service Provider for the Services;
  - (IV) the number of requests received by the USF Service Provider for the Services that remain outstanding; and
  - (V) the average time it takes for the USF Service Provider to fulfil a request for the Services; and
- (vi) such other information as determined by the Relationship Liaison Committee.
- (b) The Reports shall be filed by the USF Service Provider with USFCo within 30 days of the end of the relevant quarter.
- (c) The Reports shall be in a form satisfactory to the USFCo. Any disputes regarding the form of the reports shall be handled in accordance with Article Ten.
- (d) The USF Service Provider shall also provide Quarterly progress reports and real-time remote access to the USFCo and the Technical Auditor in an agreed manner and medium for;
  - (i) Bandwidth usage; and
  - (ii) Quality of Service of USF Optic Fiber Network and USF OFC Services.

## **ARTICLE TEN - DISPUTE RESOLUTION**

### **10.01 Dispute Escalation Process**

- (a) The Parties shall act reasonably in interpreting this Agreement and the Schedules hereto. In the event of a dispute under this Agreement, the Parties will first engage in the dispute escalation processes identified in this Section 10.01. The Parties also agree to use reasonable good faith efforts to resolve all disputes.
- (b) **Resolution by Relationship Managers**
  - (i) Each of the Parties will appoint managers (each a "Relationship Manager") within 30 days of the Effective Date. Each Relationship Manager will be familiar with this Agreement and related documentation. If a Party replaces or reassigns its Relationship Manager, that Party will immediately notify the other Party of the change.



- (ii) Either Party may refer a dispute to the Relationship Managers by preparing a written notice describing the nature of the dispute and summarizing related information (the “Dispute Notice”). The Relationship Managers will meet within three Business Days of receipt of the Dispute Notice to review the information with the objective of resolving the dispute.

(c) **Resolution by Relationship Liaison Committee**

- (i) A committee (the “Relationship Liaison Committee”) will be formed by the Parties and shall consist of an equal number of representatives appointed by each of the Parties.
- (ii) If the Relationship Managers are unable to resolve the dispute within ten Business Days of the receipt of the Dispute Notice, either Relationship Manager may refer the matter to the Relationship Liaison Committee by written notice to the other Relationship Managers. Within five Business Days of the Relationship Liaison Committee’s receipt of such referral, the Relationship Liaison Committee shall meet with the objective of resolving the dispute. A representative of each of the Parties shall co-chair each meeting. Minutes of each meeting will be taken.
- (iii) The Relationship Liaison Committee will have the discretion to form additional committees or subcommittees for any purpose it deems appropriate, with the ultimate objective of resolving the dispute.
- (iv) The Relationship Liaison Committee or any additional committees or subcommittees formed by the Relationship Liaison Committee in relation to the dispute will, at either Party’s reasonable request, meet as often as reasonably required with the objective of resolving the dispute. Minutes of all meetings will be taken.

(d) **Resolution by Relationship Executive Committee**

- (i) A committee (the “Relationship Executive Committee”) will be formed by the Parties and shall include USFCo’s Chief Executive Officer and the USF Service Provider’s [●]. [*title of appropriate executive officer of winning bidder to be inserted*]
- (ii) If the Relationship Liaison Committee is unable to resolve the dispute within fifteen Business Days of the receipt of the Dispute Notice, either Party may refer the matter to the Relationship Executive Committee by written notice to the other Party. Within five Business Days of the Relationship Executive Committee’s receipt of such referral, USFCo’s Chief Executive Officer will meet with the USF Service Provider’s [●] with the object of resolving the dispute. Minutes of the meeting shall be taken.



- (iii) If the Relationship Executive Committee is unable to resolve the dispute within fifteen Business Days of the receipt of the Dispute Notice, then either Party may:
- (I) refer the dispute to the Appeal Committee in accordance with Section 10.02; or
  - (II) commence arbitration or court proceedings in accordance with Section 10.03.

#### 10.02 **Referral to Appeal Committee**

Any dispute that has not been resolved by application of the Disputes Escalation Process described in Section 10.01 may be referred to the Appeal Committee to be constituted pursuant to Rule 31 of the USF Rules.

#### 10.03 **Arbitration or Court Proceedings**

Any dispute that has not been resolved by application of the Disputes Escalation Process described in Section 10.01, or that is not pending before the Appeal Committee pursuant to Section 10.02, may become the subject of arbitration or court proceedings commenced by either Party in accordance with applicable rules and procedures.

#### 10.04 **Dispute Resolution Costs**

The Parties shall be responsible for their own dispute resolution costs, unless the arbitrator or court orders otherwise.

#### 10.05 **Exemption from Dispute Resolution Processes**

Notwithstanding anything to the contrary in this Agreement:

- (a) Neither Party will be required to use the dispute escalation process described in Section 10.01 for disputes requiring injunctive relief or other urgent relief.
- (b) The dispute resolution processes described in this Article Ten apply only to disputes arising under this Agreement. They do not apply to disputes arising under any licence, the Act or any other regulatory matters, which shall be dealt with by PTA in accordance with the Act and applicable PTA regulations and procedures.
- (c) Nothing in this Article Ten derogates from PTA's rights or powers under the Act. The provisions of Article 10 are subject to the Act and any regulations made there under. For greater certainty, if and to the extent there are conflicts in the interpretation or application of any of the provisions of this Article 10 with the provisions of the Act or related regulations, the Act and regulations shall prevail.

## **ARTICLE ELEVEN - REPRESENTATIONS AND WARRANTIES**

### **11.01 Mutual Representations and Warranties**

Each of the USF Service Provider and the USFCo represents and warrants to the other that:

- (a) it is duly organized and validly existing under the laws of Pakistan;
- (b) that it has all right and authorization, and has obtained all consents necessary or desirable to execute, deliver and perform this Agreement;
- (c) nothing in this Agreement, nor the performance of any obligations thereunder, will conflict with such party's Constating Instruments, any law or any other person's rights; and
- (d) to the best of its knowledge, there are no pending suits threatened against such party that would affect the USF Services or the performance of obligations under this Agreement.

### **11.02 Representations and Warranties of USF Service Provider**

The USF Service Provider further represents and warrants to USFCo that:

- (a) unless the USF Service Provider obtains USFCo's prior written approval, all telecommunications facilities and equipment installed by the USF Service Provider in its USF Network shall be new when first installed and shall comply with Pakistani type-approval requirements and internationally recognized standards;
- (b) the USF Network constructed by it and the USF Services provided by it shall at all times comply with all applicable Pakistani laws and regulations including, but not limited to, telecommunications, environmental, import and export regulations;
- (c) all telecommunications facilities and equipment installed by the USF Service Provider in its USF Network will be maintained by the USF Service Provider in good working order, ordinary wear and tear excepted;
- (d) the USF Network constructed by it and the USF Services provided by it will meet or exceed the specifications identified in the Proposal;
- (e) it has, and will have (either by itself, or in conjunction with its affiliates, or its subcontractors), the skills, qualifications, expertise and experience necessary to construct and operate the USF Network and perform and manage the USF Services in accordance with this Agreement;
- (f) all representations and warranties made in the Proposal as to facts materially related to the USF Network and USF Services, including facts pertaining to the USF Service Provider's corporate structure, organization, operations, general

skills and capabilities relevant to the USF Network and USF Services, remain true and correct and will be observed by the USF Service Provider in all material respects; and

- (g) the USF Service Provider is under no current obligation or restriction, nor will it knowingly assume any such obligation or restriction, that does or would in any way interfere or conflict with the operation of this Agreement.

## **ARTICLE TWELVE - INDEMNIFICATION**

### **12.01 Indemnification**

- (a) The USF Service Provider hereby indemnifies and agrees to save harmless Universal Service Fund, USFCo and GoP from any and all claims, damages, judgments, liens, suits, costs and expenses of any nature or kind whatsoever that may be successfully claimed or asserted by any person against USFCo arising out of, or in connection with, the implementation or operation of the USF Network or the supply or failure to supply the USF Services.
- (b) The USF Service Provider's obligation to indemnify and hold USFCo harmless is contingent on USFCo giving the USF Service Provider prompt notice of any event giving rise to such a claim (an "Indemnification Notice") and giving the USF Service Provider the authority to conduct the defence of any legal action arising therefrom, provided however that USFCo may assist the USF Service Provider in such defence at its own expense and retain additional counsel at its own expense to observe or participate in any such litigation.

## **ARTICLE THIRTEEN - FORCE MAJEURE**

### **13.01 Force Majeure**

- (a) If and to the extent that a Party's performance of any of its obligations pursuant to this Agreement is prevented, hindered or delayed by reason of a Force Majeure Event and such non-performance, hindrance or delay could not have been prevented by reasonable foresight or precautions, and cannot reasonably be circumvented through the use of alternate sources, work-around plans or other means, then the non-performing, hindered or delayed Party may give written notice (a "Force Majeure Notice") to the other Party.
- (b) A Force Majeure Notice shall contain reasonable particulars of the Force Majeure Event in question and the effect of such Force Majeure Event as it relates to the obligations of the non-performing, hindered or delayed Party hereunder.
- (c) Within 10 Business Days of receipt of the Force Majeure Notice, the other Party shall either:
  - (i) certify in writing (a "Force Majeure Certification") to the non-performing, hindered or delayed Party that a Force Majeure Event has occurred; or

- (ii) indicate in writing to the non-performing, hindered or delayed Party that a Force Majeure Event has not occurred, providing reasons for this conclusion.
- (d) Where the other Party has issued a Force Majeure Certification in response to a Force Majeure Notice in accordance with Section 13.01(c), the Parties may agree to amend this Agreement in such a way that adapts to the circumstances of the Force Majeure Event while providing similar value for money as the original Agreement and achieving the objective of extending USF Network facilities and USF Services into unserved communities that do not then have access to such types and capacities of telecommunications facilities and services.
- (e) Where the other Party has not issued a Force Majeure Certification in response to a Force Majeure Notice in accordance with Section 13.01(c), the non-performing, hindered or delayed Party may give a copy of the Force Majeure Notice to the Technical Auditor, provided that it notifies the other Party in writing that it has elected to do so.
- (f) Within 10 Business Days of receipt of the Force Majeure Notice, the Technical Auditor will either:
  - (i) issue a Force Majeure Certification indicating to the Parties that a Force Majeure Event has occurred and whether a Technical Amendment to this Agreement is required in accordance with Section 13.02; or
  - (ii) indicate in writing to the Parties that a Force Majeure Event has not occurred, providing reasons for this conclusion.
- (g) Where a Force Majeure Certification has been issued in response to the Force Majeure Notice of either Party, such non-performance, hindrance or delay, as applicable, of those obligations affected by the Force Majeure Event will not constitute a default hereunder by that Party for as long as such Force Majeure Event continues and such Party continues to use its reasonable commercial efforts to re-commence performance whenever and to whatever extent possible without delay, including through the use of alternate sources, workaround plans or other means.
- (h) For the purpose of this Agreement, “Force Majeure Event” means any of the following events beyond the control of the Parties:
  - (i) With respect to the obligations of both parties:
    - (I) lightning, storms, earthquakes, landslides, floods, tsunami, washouts and other Acts of God;
    - (II) strikes, lockouts or other industrial disturbances of the party;

- (III) civil disturbances, sabotage, war, blockades, insurrections, terrorist actions, vandalism, riots, epidemics;
  - (IV) any law, order proclamation, regulation, ordinance, demand or requirement of any governmental authority;
  - (V) any other material event that could reasonably be considered to be force majeure by reason that it is beyond the control of the Party affected; and
- (ii) With respect to the obligations of the USF Service Provider alone, substantial or material fires, explosions, breakage of or other accidents to plant, machinery, equipment or other facilities of the USF Service Provider;

but does not include the inability of either Party to obtain financing or any other financial inability on the part of either Party.

### 13.02 **Technical Amendments**

- (a) Where the Technical Auditor issues a Force Majeure Certification to the Parties in accordance with Section 13.01, indicating that a Force Majeure Event has prevented the implementation, activation or operation of the USF Network or the provision of the USF Services in certain parts of the USF Areas described in Schedule C or in accordance with the implementation and payment schedule described in Schedule D, the Technical Auditor may prepare proposed amendments to one or more of Schedules C and D, and submit the proposed amendments (a “Technical Amendment”) in writing to the Parties.
- (b) If the Technical Auditor submits a Technical Amendment in accordance with Section 13.02(a), then one or more of the following Schedules to this Agreement may also be the subject of amendments to be proposed by the Technical Auditor, to the extent that, in the professional opinion of the Technical Auditor, such further amendments are required by the Technical Amendment:
- (i) Schedule A – Fiber Optic Connectivity with unserved Tehsil Headquarters, Availability and Quality Specifications;
  - (ii) Schedule B – Proposed Traffic Matrix (Bandwidth Capacities) for each Fiber Optic Link included in Schedule C, Availability and Quality Specifications;
  - (iii) Schedule F – Performance Bond.
- (c) Notwithstanding any other provisions of this Article, any Technical Amendment must be prepared by the Technical Auditor in accordance with the following:
- (i) the Technical Auditor shall consult with USFCo and the USF Service Provider prior to submitting the Technical Amendment;

- (ii) the Technical Amendment shall, in the professional opinion of the Technical Auditor, provide similar value for money as the original Schedule C and other Schedules to this Agreement, and achieve substantially the same universal service objectives; and
  - (iii) the Technical Amendment shall not increase the costs of implementing the USF Network or providing the USF Services.
- (d) Any dispute regarding a Technical Amendment submitted by the Technical Auditor shall be handled in accordance with Article Ten.

### 13.03 **No Payment for Unperformed Services**

- (a) If the USF Service Provider fails to construct the USF Network or provide the USF Services in accordance with this Agreement due to a Force Majeure Event, any USF Subsidy payments will be adjusted in a manner such that USFCo is not responsible for any payment for a Project Implementation Milestone that the USF Service Provider fails to meet.
- (b) Where a Project Implementation Milestone is only partially completed due to a Force Majeure Event for which a Force Majeure Certification has been issued, and the Force Majeure Event is likely to continue for a substantial period of time, the payment for such Project Implementation Milestone for the period of the Force Majeure Event will be adjusted on an equitable basis taking into account, among other things, the length of the resulting delay and the progress achieved towards the Project Implementation Milestone.

### 13.04 **Duration of Force Majeure Event Beyond Six Months**

Notwithstanding anything to the contrary in this Agreement, if a Force Majeure Event during which the USF Service Provider is unable to complete one or more Project Implementation Milestones in accordance with this Agreement, lasts for more than six months, then:

- (a) subject to section 13.03(b), USFCo will have no obligation whatsoever to pay part of the USF Subsidy for the uncompleted work or any future work of the USF Service Provider under this Agreement; and
- (b) the USF Service Provider may be deemed by USFCo to be in material breach of this Agreement in accordance with section 15.03, at USFCo's sole discretion; however, USFCo shall not be entitled to exercise any of the remedies identified in Sections 4.01 and 4.02 in connection with the circumstances of the Force Majeure event.

## **ARTICLE FOURTEEN - CONFIDENTIALITY**

### **14.01 Confidentiality**

Except as specifically provided for in this Agreement or as required by applicable laws or regulation, or, neither USFCo nor the USF Service Provider, nor any of their respective employees, agents, servants or subcontractors may disclose any confidential or trade secret information provided by one to the other with respect to the USF Network or the USF Services or any other matter pertaining to this Agreement without the prior written consent of the other. Each party must retain such information in strict confidence for the benefit of the other party, provided that the foregoing will not apply to any information that either party establishes as being already in the public domain or already known to the party receiving the information, without violation of this Agreement.

## **ARTICLE FIFTEEN - TERM AND TERMINATION**

### **15.01 Term**

This Agreement commences on the Effective Date and continues for a term of ten (10) years ending on [•], 2022 (the “Term”).

### **15.02 Termination – Bankruptcy, Winding Up, Etc.**

- (a) This Agreement and the rights and obligations of each Party contained herein may be terminated by USFCo giving notice to the USF Service Provider forthwith upon the happening of any of the following events of default:
  - (i) where the USF Service Provider takes any action in respect of liquidation or winding up, or makes an assignment for the benefit of creditors, or if a winding up, bankruptcy or similar petition under the Companies Ordinance is filed or presented by the USF Service Provider in respect of its properties or assets, or a judgment or order is entered by any court of competent jurisdiction approving any such petition or petition seeking the reorganization, arrangement or composition of or in respect to the USF Service Provider or its debts or obligations, or if a custodian or receiver or receiver and manager or any other official with similar powers be appointed for the USF Service Provider or a substantial portion of its properties or assets and such appointment is not dismissed or discharged within 30 days thereof; or
  - (ii) where a winding up, bankruptcy or similar petition with respect to an enforced liquidation of the USF Service Provider is presented or filed against it unless the same is dismissed or discharged within 30 days, during which grace period execution thereunder is effectively stayed.
- (b) If an event of default pursuant to Section 15.02(a) occurs and USFCo wishes to terminate this Agreement, USFCo must give the USF Service Provider notice of its decision to terminate within 60 days of such default coming to its attention.



### 15.03 **Termination – Material Breach**

- (a) Subject to Section 15.03(b), if any Party commits a material breach of this Agreement, the Parties agree that the other Party not in default has the right to terminate the Agreement; provided that the Party not in default gives the other Party who is in default not less than 30 days prior written notice of the default complained of during which period the Party alleged to be in default has an opportunity to cure the same and if the default is cured within such period, the other Party is not entitled to terminate the Agreement.
- (b) Schedule E is a list of defaults which the Parties acknowledge as constituting material events of default and for which the other party should be entitled to terminate the Agreement pursuant to this Section 15.03.

### 15.04 **Termination – Remedies**

- (a) On termination by the USFCo pursuant to Sections 15.02 or 15.03, the USFCo shall be entitled to exercise any of the remedies identified in Sections 4.01 and 4.02 that are applicable in the circumstances of the performance failure leading to the termination.
- (b) On termination by the USF Service Provider pursuant to Section 15.03, the USF Service Provider shall be entitled to payment of all USF Subsidy instalments payable pursuant to Schedule D for Project Implementation Milestones achieved prior to the effective date of termination.
- (c) The provisions of this Article Fifteen as to termination do not limit or restrict the rights of either party, to seek other remedies or take measures that may be otherwise available to it at law or equity in connection with the enforcement and performance of obligations under this Agreement.

## **ARTICLE SIXTEEN - GENERAL**

### 16.01 **Records, Audit and Inspection**

- (a) The USF Service Provider shall maintain all records required for preparation of the reports described in Section 9.01. The USF Service Provider shall also maintain complete records of its network plans, contracts entered into, expenses incurred in connection with the implementation of the USF Network and the provision of the USF Services, and any other records required for compliance with its obligations under this Agreement.
- (b) USFCo shall have the right to send its auditors or other appointed representatives, on at least 24 hours prior notice, to the USF Service Provider's places of business for the purpose of auditing or otherwise inspecting the information and records of the USF Service Provider pertaining in any way to the performance of this Agreement.



**16.02 Time of the Essence**

Time is of the essence of this Agreement.

**16.03 Expenses**

Each of the Parties hereto will pay their respective legal and accounting costs and expenses incurred in connection with the preparation, execution and delivery of this Agreement and all documents and instruments executed pursuant hereto and any other costs and expenses whatsoever and howsoever incurred.

**16.04 Public Announcements**

No public announcement or press release concerning this Agreement will be made by the USF Service Provider without the prior consent and approval of USFCo.

**16.05 Benefit of the Agreement**

This Agreement will inure to the benefit of and be binding upon the respective heirs, executors, administrators, successors and permitted assigns of the Parties hereto.

**16.06 Entire Agreement**

This Agreement constitutes the entire agreement between the Parties hereto with respect to the subject matter hereof and cancels and supersedes any prior understandings and agreements between the Parties hereto with respect thereto. There are no representations, warranties, terms, conditions, undertakings or collateral agreements, express, implied or statutory, between the Parties other than as expressly set forth in this Agreement.

**16.07 Severability**

If any provision of this Agreement is determined to be invalid or unenforceable in whole or in part, such invalidity or unenforceability will attach only to such provision or part thereof and the remaining part of such provision and all other provisions hereof will continue in full force and effect. In the event of any such invalidity or unenforceability, the Parties agree to engage in good faith efforts to determine any amendments to the Agreement required to preserve its intended purpose and effect.

**16.08 Amendments and Waiver**

No modification of or amendment to this Agreement is valid or binding unless set forth in writing and fully executed by both of the Parties hereto and no waiver of any breach of any term or provision of this Agreement is effective or binding unless made in writing and signed by the Party purporting to give the same and, unless otherwise provided, is limited to the specific breach waived.

### 16.09 **Assignment**

This Agreement may not be assigned by the USF Service Provider without the prior written consent of USFCo.

### 16.10 **Subcontractors and Other Suppliers**

Subject to Section 13.01, the USF Service Provider shall remain responsible for the due performance of this Agreement regardless of its engagement of subcontractors or other suppliers.

### 16.11 **Notices**

Any demand, notice or other communication to be given in connection with this Agreement must be given in writing and must be given by personal delivery or such other method as agreed to by the Relationship Liaison Committee, addressed to the recipient as follows:

To USFCo:

USFCo  
Fifth Floor, HBL Tower, Jinnah Avenue,  
Islamabad  
Pakistan

Attention: Chief Executive Officer

To USF Service Provider:

*[insert corporate name and address]*

Attention: *[insert title]*

or to such other address or individual as may be designated by notice given by either Party to the other. Any demand, notice or other communication given by personal delivery will be conclusively deemed to have been given on the day of actual delivery thereof.

### 16.12 **Governing Law**

- (a) This Agreement is governed by and construed in accordance with the laws of Pakistan.
- (b) Notwithstanding anything to the contrary in this Agreement:
  - (i) nothing in this Agreement derogates from USFCo's rights or powers under the Act or any rules or regulations made thereunder;
  - (ii) the provisions of this Agreement are subject to the Act, any rules or regulations made thereunder, and any Licence; and

- (iii) for greater clarity, if and to the extent there are conflicts in the interpretation or application of any of the provisions of this Agreement with the provisions of the Act, or any rules or regulations made thereunder, the provisions of the Act shall prevail.

**ARTICLE SEVENTEEN - COMPLIANCE WITH ENVIRONMENTAL LAWS.**

17.01

It shall be the responsibility of the USF Service Provider to comply with all Federal, provincial or local environmental laws, rules and regulations applicable in Pakistan.

[end of Agreement]

IN WITNESS WHEREOF the Parties have executed this Agreement.

USFCo

Per: \_\_\_\_\_  
[insert name], Chief Executive Officer  
c/s

USF SERVICE PROVIDER

Per: \_\_\_\_\_  
[insert name and title]  
c/s

SIGNED, SEALED AND DELIVERED )  
in the presence of: )

\_\_\_\_\_  
Witness for USFCo )

\_\_\_\_\_  
[insert name]

\_\_\_\_\_  
Witness for USF Service Provider )

\_\_\_\_\_  
[insert name]

## SCHEDULE A

### 1. USF Fiber Optic Network Availability and Quality Specifications

The following Fiber Optic Links shall be built in the USF defined areas identified in Schedule C to provide the minimum bandwidth capacities identified in Schedule B as per USF specifications attached. The minimum capacities proposed for Fiber Optic equipment are just to facilitate the applicants and they will make their own analysis to propose adequate higher capacities.

The system capacities have been proposed based on the following data.

1. Population of Tehsil HQ/Cities
2. F.O Capacity at nearest point of connectivity
3. Strategic importance
4. Cities en-route having High Schools or Colleges, Electricity, Health Centre and Post Offices with minimum population of 10,000 or Cantonment Areas have also been considered for F.O Connectivity

In case the capacities fall short of the requirements, the USF service provider shall upgrade the F.O systems pro- actively in minimum possible time, but not later than three months period to meet the requirements.

S/N	NAME OF FIBER OPTIC LINK	SDH EQUIPMENT							
		STM-64		STM-16		STM-4		STM-1	
		TM	ADM	TM	ADM	TM	ADM	TM	ADM
1	TMG-KHAL-WARRI-DARRORA-DIR-DROSH-CHITRAL		07						
2	CHITRAL-BOONI-MASTUJ		01		01			01	
3	MAYAR-SAMRBAGH						01	01	
4	KHAWAZAKHELA-BAR ALUPRI				02				
5	BAR ALUPRI-KUZALPURI-ALOOCH(PURAN)				01	01	01		
6	CHAKESAR-KARORA-BESHAM				02	01			
7	CHAKESAR-MARTUNG				01			01	
8	ALOOCH(PURAN)-MARTUNG						01	01	
9	GARAMCHASMA-CHITRAL					01	01		
10	SHAHGRAM-BOONI					01	01		
11	WARIJUN-BOONI					01	01		
12	HATHALA - KULACHI -- DARABAN					02	01		

13	KECH – PAHARPUR (Option 1)					02			
13a	DIK (Bannu Road Exchange) -- DOHOTAR -- PAHARPUR ( Option 2)					02	01		
14	THAKOT – BANNA (ALLAI)					02			
15	THAKOT – DAUR MIRAN – JUDBA ( KALA DHAKA )					02	01		
16	PATTAN -- PALAS					01	01		
17	PATTAN—DAASU					01	01		

## **2. Service Availability**

- a) The USF Fiber Optic Network and USF FOC Services shall become available in all of the un-served Tehsil Headquarters and cities identified in Schedule C as being mandatory for USF Fiber Optic Network and USF FOC Services in accordance with the USF Project Implementation Milestones identified in Schedule D.
- b) The USF Service Provider shall ensure that the USF FOC Services are maintained and continued, and meet applicable service requirements and quality of service standards, throughout the Term of the SSA
- c) The USF Service provider shall establish proper maintenance and operation centers with qualified and well equipped teams for the efficient management and operation of the USF FON and USF FOC services.

## **3. Quality of Service**

- a) Quality Criteria for USF FOC Services – The USF Service Provider shall meet all quality of service requirements for the USF FOC Services identified in the USF Service Provider’s Licence(s), or otherwise established by the PTA.
- b) Quality of Service Reporting for USF FOC Services – Quality of service reports for the USF FOC Services shall be provided in accordance with Section 9.01 of the Agreement and any requirements for quality of service reporting established by the PTA.

## **Schedule A (Part – II)**

# **USF Telecommunications Networks and Services Project, “Fiber Optic Connectivity up to Tehsil Level”**

**Technical Specifications/Rev.1/September 09**

## A. Optical Fibre Cable Specifications

### 1. Introduction

This specification covers the minimum standards and requirements for the optical fiber cables to be used in the USF telecommunications networks of Pakistan. The F.O cable shall be direct buried type, aerial cable type or hauled into ducts type as may be determined after survey by the Bidder and its characteristics shall be compatible with the existing F. O cables in the network.

### 2. Definitions

Definitions applied throughout this specification are as follow: -

- i) "Fiber"  
The drawn coated optical fiber
- ii) "Primary Coating"  
The first layer of inert material applied to the fiber immediately after being drawn from a perform and can be readily removed for splicing purpose without damage to the fiber.
- iii) "Strength Member"  
The component of the assembled cable which is designed to provide sufficient strength to the cable to ensure that the fibers are not strained beyond their permissible limits
- iv) "Wrapping"  
Non-metallic barrier tape, which surrounds the cable core
- v) "Fiber Core"  
The central region of the optical fiber through which most of the optical power is transmitted.
- vi) "Cladding"  
The dielectric material of an optical fiber surrounding the core with a different refractive index from core
- vii) "Non-Circularity of the Cladding Surface"  
The difference between the maximum cladding surface diameter ( $D_{max}$ ) and minimum cladding surface diameter ( $D_{min}$ ) divided by the nominal cladding diameter ( $D$ ).
- viii) "Core / Cladding Concentricity Error"  
The distance between the core centre and the cladding centre divided by the core diameter
- ix) "Refractive Index Profile"  
The distribution of the refractive index along the diameter of an optical fiber
- x) "Attenuation Coefficient"  
It is the attenuation of the fiber per unit length. It is expressed in dB/Km.
- xi) "Chromatic Dispersion"



The spreading of light pulse per unit source spectrum width in optical fiber caused by the different group velocities of different wavelengths composing the source spectrum

- xii) “Cutoff Wavelength”  
The cutoff wavelength is the wavelength at which the mode ceases to propagate in the fiber.
- xiii) “Chromatic Dispersion Coefficient”  
The Chromatic dispersion per unit source spectrum width and unit length of fiber, it is expressed in ps/nm.km.
- xiv) “Zero Dispersion Wavelength”  
The wavelength at which the chromatic dispersion vanishes
- xv) “Zero Dispersion Slope”  
The slope of the chromatic dispersion coefficient versus wavelength curve at zero dispersion wavelengths
- xvi) “Polarization Mode Dispersion (PMD)”  
Dispersion of an optical signal due to the different polarizations of light traveling at different speeds through optical fiber

### 3. Optical Fiber Cables

- a) All optical fibers shall maintain their geometrical properties for the required life, 25 years of the cable.
- b) The value of the mode field diameter shall be within 8.6-9.5  $\mu\text{m}$ . The mode field diameter deviation shall not exceed  $\pm 0.7\mu\text{m}$ .
- c) The mode field concentricity error shall not be more than 1.0  $\mu\text{m}$ .
- d) The cladding diameter shall be  $125 \pm 1\mu\text{m}$ .
- e) The cladding non-circularity shall not exceed 2.0%.
- f) Core/clad concentricity error shall not exceed 0.8 $\mu\text{m}$ .
- g) Macro bending loss shall be measured by forming 100 turns of fiber on a mandrel of 75mm diameter. The attenuation increase shall not exceed 0.5 dB at 1550 nm.
- h) The minimum bending radius shall not be less than 10-12 times outer diameter of the cable
- i) No jointed fibers are allowed in cable according to this specification.
- j) The diameter of the coating shall be  $250 \pm 15 \mu\text{m}$ .
- k) Fiber optic cable shall be supplied in nominal lengths of four (4) km
- l) The splice loss of 0.02dB for SM is desirable however; maximum value of splice loss shall not exceed 0.05 dB for SM fiber.
- m) The Optical Fiber Cable shall qualify International test standards for Tensile Test, Temperature Cycling Test, Crush Strength Test, Impact Test ,Repeated Bending Test and Torsion Test

## 4. Optical Transmission Requirements

### i) Optical Attenuation Properties

The attenuation properties of the optical fibers shall conform to the following values specified below.

Design Parameter	Maximum Values at room temperature
Wavelength of Light (nm)	1285-1330 1310 1550
Attenuation for individual Fibers (dB/km)	$\leq 0.4 \leq 0.38 \leq 0.25$
Average attenuation for the Cable (dB/km )	$\leq 0.38 \leq 0.35 \leq 0.21$

### ii) Cutoff Wavelength

The F.O Cable cutoff wavelength shall not exceed 1260 nm.

### iii) Chromatic Dispersion

Chromatic dispersion shall not exceed 3.5 ps/nm.km between 1285 nm and 1330 nm and 18 ps/nm.km at 1550 nm.

### iv) Attenuation Uniformity

The attenuation of the fiber shall be distributed uniformly along the fiber length such that there are no localized discontinuities in excess of 0.1 dB at any of the design wavelengths.

### v) Polarization Mode Dispersion

Polarization mode dispersion (PMD) coefficient of cable shall not exceed 0.5ps/ $\sqrt{\text{km}}$  for an electrical regeneration section of 400 km of installed fiber. Differential Group Delay (DGD) shall not exceed 10ps for a maximum section length of 640 km.

## B. Optical Fibre Cable Laying Specifications

### 1. Introduction

This specifies the technical parameters for laying or installation of Optical Fiber Cable in USF defined areas of Pakistan as stated in Schedule C to SSA.

### 2. Scope of Work

This covers laying of O.F cable as direct buried or ducted or as aerial installation as the case may be, including all civil works, in different terrains throughout the defined USF areas. The provision of sand, bricks, PVC pipes / HDPE pipes /or equivalent , GI pipes sub ducted with PVC/ HDPE pipes /or equivalent, bridge attachments, cement, slabs, route indicators, Posts, accessories and materials, cable trays, machinery, transport ,Joint enclosures, ROW and test equipment etc shall be the responsibility of the USF Service provider. In city areas the underground duct system shall be built with necessary hand holes for the laying of OFC. In hilly areas or other locations not suitable for direct buried or ducted type F.O cables, aerial fiber optic cable may be used with proper and secure installations. The Fiber optic cable routes have been defined in Schedule C to SSA for implementation.

### 3. Direct Buried Optical Fiber Cable

- a. Cable section lengths must allow for looping the cable at splice closure locations.
- b. Care should be taken to ensure that cable attachment systems are specifically designed for optical fiber cable and do not transmit stress to the fiber
- c. Care is required to counter cable movement in steep approach sections or vertical sections. This type of movement which can be produced by traffic vibrations could lead to excessive fiber strain and suitable cable restraints should be used
- d. Where a trench method is used, back filling materials and practices may require particular consideration so that fiber strain limits are not reached during this operation.

#### 3.1 Excavation of Trench

- 3.1.1 The trench shall be excavated to a depth of 1.5m except rocky areas; the trench shall be graded to enable the cable to be laid on an even plain. The width of the trench shall be 40cm at the top and 35-40cm at the bed. The depth reference for the trench shall be taken from the road surface or the normal earth surface level which one is lower.
- 3.1.2 A bed of sand 10 cm deep shall be laid along the bottom of the trench and cable shall be placed at the centre of trench.
- 3.1.3 A sand bed 10 cm deep shall be provided above the cable.
- 3.1.4 Bricks shall be placed transversally on the cable with no space between the bricks. See Fig.1

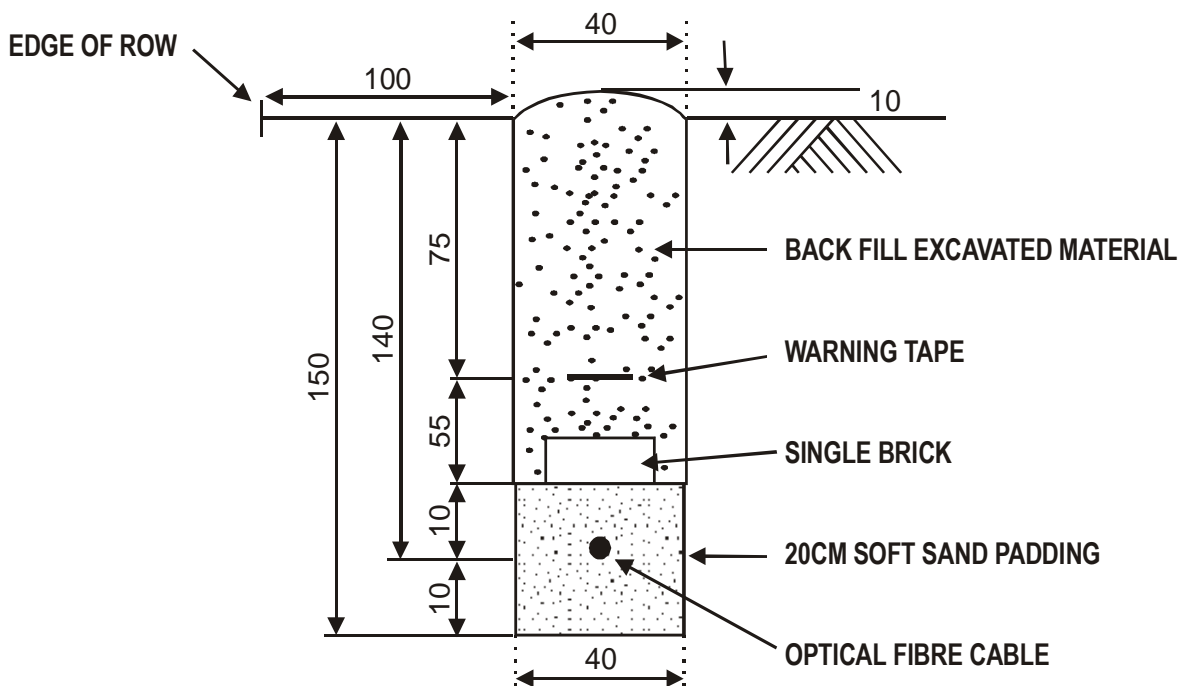

Note: All dimensions are in cm.

Fig.1. Direct Buried Cable

### 3.2 Standing Water Area

There will be locations where still water ponds fall along the trench alignment. In such area, the following procedure shall be followed.

- 3.2.1 If the height of water is 1 meter or above and is not seasonal water but permanent then cable shall be laid directly on the surface of the earth and slabs with cement sand ratio 1:8 (100x50x20cm bag size) shall be placed longitudinally. See Fig.2

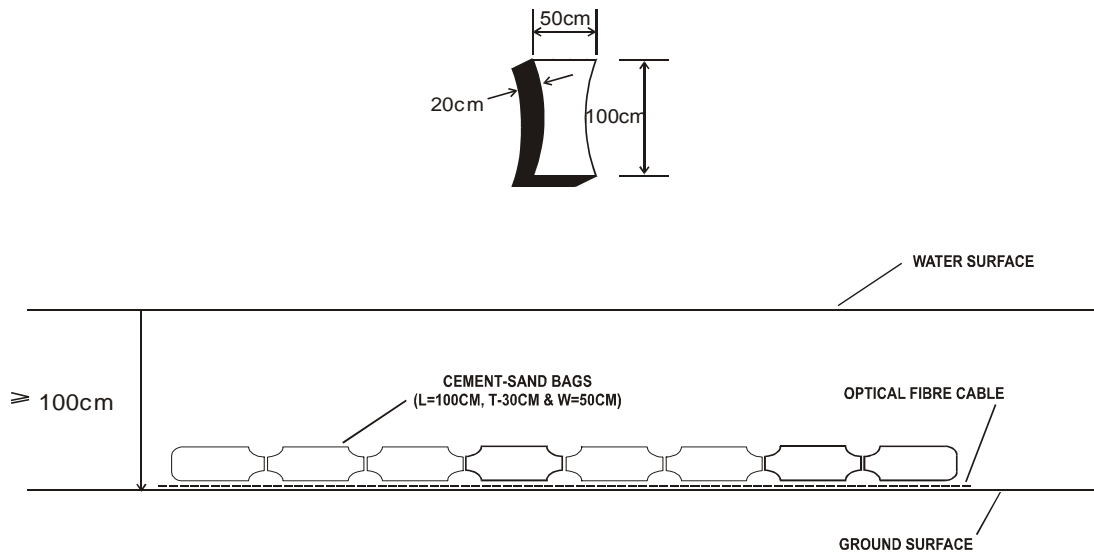
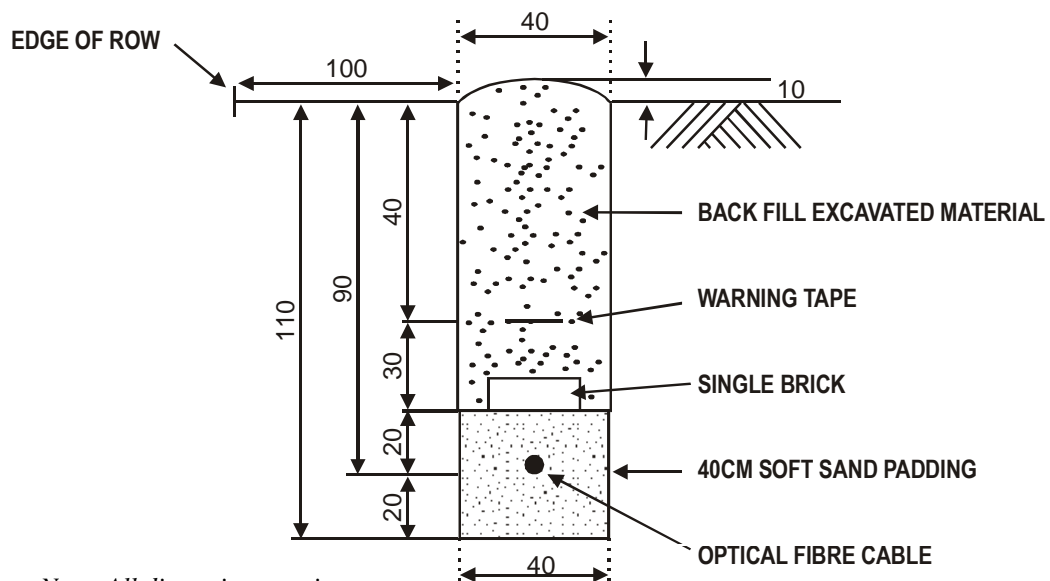

Fig.2. Sand-Cement Bags

### 3.3 Rocky Soil

- 3.3.1 In rocky area, the trench depth shall be 110 cm, width 40 cm at the top and 35-40 cm at the bed with all the sharp edges of rock removed. Sand cushion 20cm thick above and below the cable shall be provided. Bricks shall be placed as in the case of normal soil. See Fig.3



Note: All dimensions are in cm.

Fig.3 Direct Buried Cable in Rocky Area

- 3.3.2 There will be situations where it is not practical to excavate in extremely hard rock to a depth of 1.1 meter. For such areas, the depth of the trench may be kept as 90 cm including 10 cm concreting at the top.

### **3.4 GI Pipe sub ducted with PVC/HDPE or equivalent**

Throughout the execution of the project GI pipe sub-ducted with PVC pipe / HDPE or equivalent shall be installed on bridges, culverts that require attachments, under rivers, railway lines, highways, canals, rain washable area, and heavy traffic passing area e.g. Petrol pumps etc, In all three cases the minimum separation between the existing service and the Optical fiber Cable shall be 100cm. Under no circumstances the cable shall be installed above an existing service.

### **3.5 Warning Tape**

A suitable yellow PVC tape 0.5 mm thick and 100 mm wide shall be placed 30 cm above the installed optical fiber cable for indication to the excavators of the presence of optical fiber cable with some warning note.

### **3.6 Route Indicators**

Route markers are to be installed along the cable route at locations visible from the previous marker or 100 meters apart and at turning points where cable route changes direction.

### **3.7 Cable Joint Pit Markers**

Cable Joint Pit markers are to be installed at all joint pit locations. It is important that all locations of joint pits are recorded and have a reference location measurement.

### **3.8 Slabs (50X30X10CM AND 100X30X10CM)**

The slab of 50x30x10cm shall be used in a joint pit. The slab of 100x30x10 cm shall be used along the route at small culverts, loops at the bridges and over cable laid along places where there could be damage to the cable.

## **4. Ducted Optical Fiber Cable**

FO cable shall be laid in ducts with two inches diameter, 2 way PVC pipes /**HDPE or equivalent** along with appropriate HHs. Minimum wall thickness shall not be less than 3.5mm.

On completion of the duct line between any two jointing chambers, a cylindrical brush and an iron test mandrel shall be passed once through each way to test the duct and remove any foreign matter which may have entered. Pressure testing for duct ways shall be carried out. After the last joint has been completed in each way, pressure plugs shall be inserted at each end and tightened.

Section 3 to this Technical Specifications report lists direct buried cable laying specifications. Same specifications, except the bricks arrangement, shall be followed for Duct laying. In areas which may be considered as sandy areas, use of sand may not be necessary for laying of ducts. A careful study shall be carried out for the laying of ducts to determine the use of sand & bricks wherever necessary.

## **5. Aerial Fiber Optic Cable**

The fiber optic cable is a high capacity transmission medium which can have its transmission characteristics degraded when subjected to excessive pulling force, sharp bends, and crushing forces. These losses may not be revealed until long after installation is complete. For these reasons extra care must be taken during the entire installation procedure.

The following information shall be used as a basic guideline for the installation of aerial fiber optic cable. It is for the personnel having prior experience in the planning, engineering, or placement of aerial cables as this does not cover all aspects of fiber optic aerial cable placement.

1. A self-supporting fiber optic cable includes messenger and carrier sections and at least one interconnecting web.

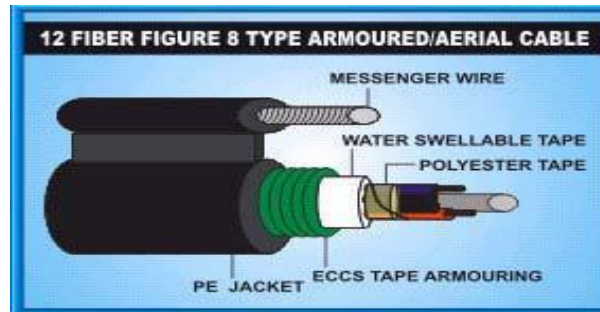

2. In order to protect the optical fiber from tensile forces and to facilitate mid-span access, the carrier section can have an over length and includes a strength member.
3. A site survey of the entire route should be performed before cable placement begins. The survey will verify construction methods, special tools required and splice locations. The characteristics of the ground along the route, trees or other obstructions shall be noted. Clearance issues over roadways, driveways, etc. need to be taken into account before cable placement begins. It will also qualify the condition and size of the existing poles to be used, the condition and size of the existing pole's anchors and reveal the need for any new poles before placement operations begins.
4. Safety cones, signs, flags, etc., should be used to channel traffic where required.
5. The fiber optic cables should occupy the uppermost available communications space on a pole, wherever possible, due to having less weight and sag than copper cables.
6. Sufficient clearances must be maintained between fiber optic cables and electrical power cables on joint-use poles, as per Electrical Safety Codes. The minimum clearance shall be one meter.
7. Splice locations shall be chosen to allow for the longest possible continuous cable spans and a minimum number of splices.
8. During cable installation, special care should be taken to not violate the minimum cable bend radius or maximum rated cable tensile load. For standard loose tube cable designs the minimum bend radius under dynamic conditions (during installation) is 15 times the cable outer diameter. The minimum bend radius under static conditions (installed) is 10 times the cable outer diameter.
9. Aerial installation should never be done in wet conditions.
10. Fiber optic cables (including all dielectric cables) shall be properly grounded when installed in the vicinity of high-voltage power cables.
11. Each jelly filled tube may contains 4 -12 fibers. Solid or stranded steel coated with polyethylene may be used as central strength member. Fiber glass reinforced plastics (FRP) may be used as central strength member if non metallic construction is required. Either aramid yarn or fiber glass shall be wound around the tube to provide physical protection and tensile strength.
12. Water blocking materials shall be filled in the interstice of the cable core, core wrapping layer/water blocking tape.
13. The un-armored type of aerial fiber optic cable is given below: The armored type normally have steel armor instead of aluminum tape beneath outer jacket.

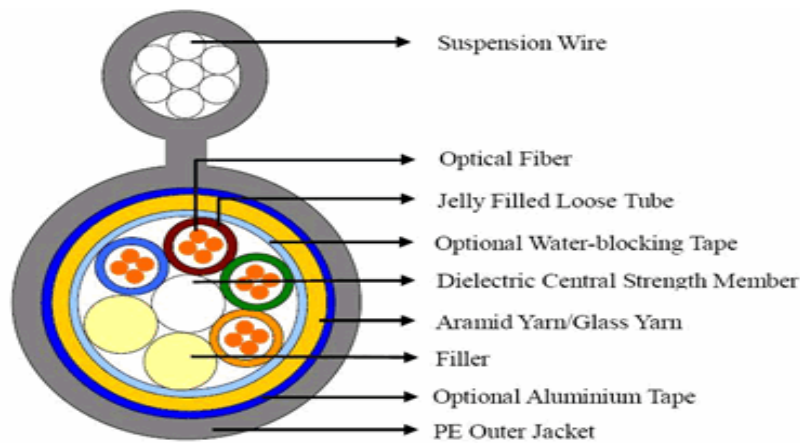

**Unarmoured Type**

14. As fiber optic cables have to be pulled into place through ducts (outdoor) or conduits (indoor), pulling eyes are to be attached to the strength members or cable outer jackets.
15. Cable structures shall protect fibers from moisture (outdoor cables), extreme temperature (aerial cables) and influx of hydrogen into the fiber.
16. The temperature range during installation and operation shall be as follows:
  - Installation: -30°C to +60°C
  - Operating: -40°C to +70°C
17. The amount of sag is dictated by clearance and tension requirements. The maximum sag shall be as follows:
  - Installation: 1 % of pole to pole distance (span length)
  - Long term installed: 3 % of pole to pole distance (span length)
18. Some extra cable may be left at the beginning and at the end of the cable run. Also, extra cable should be placed at strategic points such as junction boxes, splice cases and cable vaults. Extra cable is useful should cable repair or mid-span entry be required.
19. The cable maximum pulling tension is not to be exceeded during cable installation. In general, most cables designed for outdoor use have a strength rating of at least 600 lbs. After cable placement is complete the residual tension on the cable should be less than this value.
20. Use the method of attachment that pulls most directly on the strength material—without stressing the fiber. With indirect attachment, pulling forces are distributed over the outer portion of the cable structure.
21. The leading end of the cable should be sealed to prevent intrusion of water or other foreign material while pulling.
22. Installation procedures for open placement of fiber optic cables are the same as for electrical cables. Care should be taken to avoid sudden, excessive force so as not to violate tensile load and radius limits. Sharp bending and scraping at entrances and covers should be avoided.
23. Proper installation standards shall be followed.

## **C. Fibre Optic Line and Multiplexing Equipment**

### **1. General**

- i. The Fibre Optic Line and Multiplexer Equipment shall comply with all relevant latest ITU-T / ETSI recommendations.
- ii. The minimum capacity of the Fibre Optic Line and Multiplexing Equipment for each F.O Link shall be designed as specified in the Schedule A and C to SSA so as



- to meet the minimum traffic matrix (bandwidth) requirements specified in the Schedule B to SSA.
- iii. All equipment supplied shall be new and the manufacturer's latest generation of production equipment.
  - iv. The operation and maintenance functions of F.O transmission equipment shall be manageable through LCT and NMS for which all necessary interfaces and features shall be provided.
  - v. The engineering order wire shall be provided at all ADM and terminal locations
  - vi. The Fibre Optic equipment shall be upgradeable to higher level with out any major changes .
  - vii. The Fibre Optic equipment shall be compatible and integrate smoothly with the existing F.O Equipments in the network.
  - viii. The configuration of F.O system shall be quite flexible as Terminal or ADM.
  - ix. The protection of equipment level shall be realized by the redundancy hot swap protection for the units such as electrical interface, timing and cross-connection.
  - x. The synchronization features in equipment shall conform to the ITU latest standards.
  - xi. The Jitter and Wander characteristics shall conform to ITU latest standards.
  - xii. The System supplied shall support the Next Generation Features
  - xiii. It shall operate at a wavelength of either 1310nm or 1550nm and shall be compatible with FO cable of this project.
  - xiv. An automatic laser shutdown function shall be provided to switch the laser off in case of a break in the optical path.
  - xv. It shall have capability for direct inter-working with DWDM equipment without intermediate wavelength adapters.

## 2. Interfaces

Following interfaces shall be supported by the F.O equipment corresponding to the capacities designed for the network and as applicable in compliance to latest ITU recommendations.

- i) 2 Mb/s Electrical Interface
- ii) 34 Mb/s Electrical Interface
- iii) 45 Mb/s Electrical Interface
- iv) 140 Mbit/s electrical interfaces
- v) 155 Mbit/s electrical interface
- vi) Optical Interface, 155.520 Mbit/s.
- vii) STM-4 Optical Interface,
- viii) STM-16 Optical Interface,

### 2.1 Ethernet Interface

The offered equipment shall support the Fast Ethernet. It shall also be able to provide related technologies like Gigabit Ethernet, Resilient Packet Ring (RPR), Generic Framing Protocol (GFP), Virtual Concatenation (VCAT) and LCAS (Link Capacity Adjustment).

### 2.2 Auxiliary Interfaces

Several data interfaces shall be available as follows:



- 2.2.1 Minimum 1 x 2-wire analogue telephone interface, providing multiplex section order-wire communication at 64 Kb/s co-directional and telephone jack.
- 2.2.2 Minimum 4 x 64 Kbit/s co-directional data interfaces in compliance with ITU-T Rec. G.703 + 2 x 2 Mbit/s G.703 + 4 x RS-232 + 4 x V11 async.
- 2.2.3. Synchronization Interface : Clock input / output interface
- 2.2.4 D1~D3 and D4~D12 for network management.

### 2.3 Synchronization Interface, 2048 KHz

The electrical characteristics of the input and output of the 2048 kHz clock synchronization interface shall conform to latest ITU-T Rec. with impedance of 75 ohm unbalanced or 120 ohm balanced.

### 2.4 G.703 64 Kbit/S Data Channel Interface (Auxiliary Channel)

The electrical characteristics of the G.703 64 kbit/s interface shall conform to ITU-T Rec. G.703

### 2.5 13.8V.11 64 Kbit/S Data Channel Interface (Auxiliary Channel)

The electrical characteristics of the V.11, 64 kbit/s interface shall conform to the specifications given in ITU-T Rec. V.11.

## 3. Functional Characteristics

- a) The aggregate interface unit shall support MSP, BSHR and SNCP configurations.
- b) The LINE SYSTEM shall provide 140 Mbit/s, 155 Mbit/s (STM-1) electrical and 622 Mbit/s (STM-4) and 2.5 Gbit/s (STM-16) optical tributary interfaces.
- c) The matrix switching shall be non-blocking for all connection types. The maximum tributary capacity can be divided into four separate tributary groups. Full trib-trib connectivity shall be available within the same tributary group. The cross-connect matrix units shall support (1+1) protected configuration.
- d) The synchronization interface shall provide 2048 kHz clock input and output at 120 ohms and 75 ohm. The unit shall support 1+1 protected configuration and shall provide the following facilities and functions:
- e) The synchronization unit shall enable the Line System to be synchronized from any one of the following sources:
  - i) 2048 kHz sine or pulse external clock source (e.g. station clock). Any STM-1 (155.520 Mbit/s) tributary signal
  - ii) Any STM-4 (622.080 Mbit/s) tributary signal
  - iii) Any STM-16 (2,488.320 Mbit/s) tributary signal
  - iv) Internal clock oscillator (free-running mode).
- f) Access to a 64 kbit/s G.703 or V.11 data channel using byte F1 in the regenerator section overhead (RSOH) shall be available on the Line System.

- g) The Line System shall have a controller unit that shall be responsible for the management of the Line System. This unit shall also include the management via the F and Q-interfaces.
- h) It shall be possible to perform full remote configuration and control of any Optical Line Equipment connected to the local Optical Line Equipment using the Embedded Control Channel (ECC) of either optical aggregate. Remote operation of the system via a serial link by using a modem, or via an Ethernet link shall also be possible.

#### **4. System Configurations**

The following system configurations must be supported by the Line System:

- i) Terminal Multiplexer Mode
- ii) Add-Drop Multiplexer Mode
- iii) Regenerator Mode

#### **5. System Applications**

The Line System shall be used in the following applications:

- i) Point-To-Point
- ii) Chain Topology
- iii) Ring Topology

#### **6. Protection Switching**

- i) Multiplexer section protection switching
- ii) Sub-Network Connection Protection (SNC/P)
- iii) Bi-directional Self Healing Ring (BSHR) Protection

#### **7. Disaster Recovery**

The equipment shall have built-in recovery mechanisms to enable it to become operational in as short a time as possible following unforeseen failures, and in particular the following characteristics:

#### **8. Clock Reference**

- a) The synchronization subsystem should provide the timing reference required by all components in the network element. It should accept synchronization inputs from a number of sources:
  - (i) STM-N lines
  - (ii) 2 Mb/s traffic ports
  - (iii) 2 MHz / 2 Mbit/s external input
  - (iv) internal oscillator
- b) Automatic selection of one of such sources shall be achieved by using priority criteria. Also manual selection shall be possible.

## **D. Network Management System (NMS).**

The NMS shall support management functions according to the latest relevant ITU-T Rec.

- a) The NMS shall be able to manage Multiplexes, Line Equipment Terminals and ADM.
- b) The NMS shall support ring, multi-ring, chain, point-to-point, mesh and complex topologies.
- c) Cross connection management function shall be supported by the NMS.
- d) NMS shall support protection criteria/procedure for the port connection and paths in the network.
- e) If the USF Service provider has the existing NMS , that can be up graded to manage the F.O equipment of this project.
- f) The necessary hard ware , soft ware , data channels for the connectivity and commissioning of NMS with NEs is included.
- g) The NMS shall perform the Performance Management, Fault Management, Configuration management and Security management.
- h) This management function shall provide reports and evaluation for communication equipment status. The performance management shall have functions like Performance Data Period, Performance Event Selection, Performance Monitoring, Performance Query, Performance Threshold Setting, Performance Analysis, Performance Reporting and Database Management
- i) The NMS shall provide the capability to monitor all transmission facilities in real time.
- j) The NMS shall provide functions for the remote control and configuration of Fiber Optic equipment according to the latest relevant ITU-T Rec.
- k) NMS shall support and provides the functionalities to set up, initialize and modify the Fibre Optic equipment configuration parameters.
- l) The NMS shall support the management functions for the configuration and initialization of the F.O equipment and cards in the Network Elements .
- m) NMS shall provide the security management function to prevent network resources and equipment from unauthorized user's access
- n) The NMS supplied shall be fully compatible with the Central Network Operations Center (NoC) and fully support all the relevant protocols .

## **E. Key Performance Parameters for Fibre Optic Cable**

The USFCo Technical Auditor may perform sample testing of the following tests of Optical Fiber cable and OSP for confirming compliance to the relevant technical specifications.

- (i) Insertion Loss Test

Section: \_\_\_\_\_ A-End: \_\_\_\_\_

B-End: \_\_\_\_\_

Fibre No:	1310/1550nm		A	1310/1550nm		B	Average Loss (A+B)/2
	TX (dB)	RX (dB)	Section Loss (dB)	TX (dB)	RX (dB)	Section Loss (dB)	

Requirements:	1550nm	1310nm
Cable Attenuation per km (dB):	≤0.25	≤0.38
Average Attenuation (dB):	≤0.21	≤0.35
Maximum Splice Loss (dB)	≤0.05	≤ 0.05
Maximum Connector Loss (dB)	≤0.5	≤0.5
Total Number of Connectors:		
Total Section Loss (dB):		

(ii) Fiber Optic Cable Test Data Sheet  
(End to End Test with OTDR)

Route:

Total Optic Fiber Length (km):

Wavelength (nm):

Fiber No.	Fiber Color	From	To	Total Loss	Average Loss (db)

**CIVIL WORKS**

Section Name: \_\_\_\_\_

The civil works executed for the laying of Optical Fiber Cable shall be inspected for sample testing by the USF Technical Auditor to verify compliance to relevant Technical Specifications.

Cable Length	From:	To:	Remarks

**AERIAL WORKS**

The works executed for the installation of aerial Optical Fiber Cable shall be inspected for sample testing by the USF Technical Auditor to verify compliance to relevant Technical Specifications.

## F. Key Performance Parameters for Fibre Optic Equipment

The USFCo Technical Auditor may conduct sample testing of the tests performed during commissioning in addition but not limited to the following tests to verify the performance of the fiber optic equipment.

S.#	Description of Item	Accepted Standard	Remarks
1	<b>Protection Switching</b> (While removing the active Cross switch board, the standby board will take over the service automatically)	Switching time < 50 ms	
2	15-Minute Bit Error Performance for E1 or E3	No bit error is detected	
3	<b>24 hours BER Test</b>	<10 <sup>-10</sup> bit errors	

## **SCHEDULE B**

### **1. Traffic Matrix (Bandwidth Capacities) for various Fiber Optic Links**

The USF Service Provider shall provide the following minimum bandwidth capacities or equivalent in various Fibre Optic links proposed for connectivity to unserved Tehsil HQs in USF defined areas mentioned in schedule C and as per specifications mentioned in Schedule A and Annexure 5 to RFA.

The system capacities have been proposed based on the following points.

1. Population of Tehsil HQ
2. Fiber Optic Capacity at nearest point of connectivity
3. Diversity
4. Strategic importance
5. Cities en- route having High Schools, Electricity, Health Centre and Post offices with minimum population of 10,000 or Cantonment Areas have also been considered for F.O Connectivity

The Applicants shall make their own analysis and surveys further for meeting the minimum defined requirements .In case the capacities fall short of the requirements, the USF service provider shall upgrade the Fiber Optic systems pro- actively in minimum possible time , but not later than three months period to meet the requirements.

## 1. Timergara-Khal-Wari-Darora-Dir-Drosh-Chitral Fiber Optic Link

	Temergara			Khal			Wari			Darora			Dir			Drosh			Chitral		
	EI	FE	STMI	EI	FE	STMI	EI	FE	STMI	EI	FE	STMI	EI	FE	STMI	EI	FE	STMI	EI	FE	STMI
Temergara	-	-	-	30	2	1	20	1	1	30	1	2	30	2	4	20	2	1	40	3	8
Khal	30	2	1	-	-	-	20	-	-	20	-	-	20	1	-	20	-	-	30	1	-
Wari	20	1	1	20	-	-	-	-	-	20	1	-	20	1	-	30	-	-	30	1	-
Darora	30	1	2	20	-	-	20	1	-	-	-	-	20	1	-	20	-	-	40	1	-
Dir	30	2	4	20	1	-	20	1	-	20	1	-	-	-	-	20	1	-	40	2	-
Drosh	20	2	1	20	-	-	30	-	-	20	-	-	20	1	-	-	-	-	30	1	-
Chitral	40	3	8	30	1	-	30	1	-	40	1	-	40	2	-	30	1	-	-	-	-
Total	170	11	17	140	4	1	140	4	1	150	4	2	150	8	4	140	4	1	210	9	8

## 2. Chitral--Booni-Mastuj Fiber Optic Link

Name of Station	Chitral			Booni			Mastuj		
	EI	FE	STMI	EI	FE	STMI	EI	FE	STMI
Chitral	-	-	-	30	1	1	30	-	-
Booni	30	1	1	-	-	-	30	-	-
Mastuj	30	-	-	30	-	-	-	-	-
Total	60	1	1	60	1	1	60	-	-

## 3. Mayar-Smarbagh Fiber Optic Link

	Mayar			Samar Bagh		
	EI	FE	STMI	EI	FE	STMI
Mayar	-	-	-	40	-	-
Samar Bagh	40	-	-	-	-	-
Total	40	-	-	40	-	-

## 4. Khawazakhela-Bar Alpuri Fiber Optic link

	Khawazakhela			Bar Alpuri		
	EI	FE	STMI	EI	FE	STMI
Khawazakhela	-	-	-	126	1	1
Bar Alpuri	126	1	1	-	-	-
Total	126	1	1	126	1	1

## 5. Bar Alpuri- Kuz Alpuri-Alooch (Puran) Fiber Optic Link

	Bar Alpuri			Kuz Alpuri			Puran		
	EI	FE	STMI	EI	FE	STMI	EI	FE	STMI
Baz Alpuri	-	-	-	30	1	1	30	1	1
Kuz Alpuri	30	1	1	-	-	-	30	-	-
Puran	30	1	1	30	-	-	-	-	-
Total	60	2	2	60	1	1	60	1	1

## 6. Chakesar-Karora-Besham Fiber Optic Link

	Chakesar			Karora			Besham		
	EI	FE	STMI	EI	FE	STMI	EI	FE	STMI
Chakesar	-	-	-	40	1	2	40	1	1
Karora	40	1	2	-	-	-	30	-	-
Besham	40	1	1	30	-	-	-	-	-
Total	80	2	3	70	1	2	70	1	1



## 7. Chakesar Martung Fiber Optic link

	Chakesar			Martung		
	EI	FE	STMI	EI	FE	STMI
Chakesar	-	-	-	40		-
Martung	40		-	-	-	-
Total	40			40		

## 8. Alooch (Puran)-Martung Fiber Optic Link

	Alooch (Puran)			Martung		
	EI	FE	STMI	EI	FE	STMI
Alooch (Puran)	-	-	-	40		-
Martung	40		-	-	-	-
Total	40			40		

## 9. Garamchasma-Chitral Fiber Optic link

	Garamchasma			Chitral		
	EI	FE	STMI	EI	FE	STMI
Chitral	-	-	-	40	1	
Garamchasma	40	1		-	-	-
Total	40	1		40	1	

## 10. Shahgram-Booni Fiber Optic link

	Booni			Shahgram		
	EI	FE	STMI	EI	FE	STMI
Shahgram	-	-	-	40	1	
Booni	40	1		-	-	-
Total	40	1		40	1	

## 11. Warijun-Booni Fiber Optic link

	Booni			Warijun		
	EI	FE	STMI	EI	FE	STMI
Warijun	-	-	-	40	1	
Booni	40	1		-	-	-
Total	40	1		40	1	

## 12. Hathala – Kulachi -- Daraban Fiber Optic Link

NAME OF STATION	HATHALA		KULACHI		DARABAN	
	E-Is	FE	E-Is	FE	E-Is	FE
HATHALA	-	-	20	1	30	1
KULACHI	20	1	-	-	20	-
DARABAN	30	1	20	-	-	-
Total	50	2	40	1	50	1

## 13. Kech – Paharpur (Option 1)

NAME OF STATION	KECH			PAHARPUR		
	EI	FE	STM-1	EI	FE	STM-1
KECH	-	-	-	40	1	1
PAHARPUR	40	1	1	-	-	-
Total	40	1	1	40	1	1

## 14. Dik (Bannu Road Exchange) – Dohotar -- Paharpur (Option 2)

NAME OF STATION	DIK (BANNU ROAD EXCHANGE)		DOHOTAR		PAHARPUR	
	E-Is	FE	E-Is	FE	E-Is	FE
DIK (BANNU ROAD EXCHANGE)	--	--	20	1	30	1
DOHOTAR	20	1	--	--	20	--
PAHARPUR	30	1	20	--	--	--
Total	50	2	40	1	50	1

15. Traffic Matrix For Thakot – Banna (Allai) Fiber Optic Link

NAME OF STATION	THAKOT			BANNA (ALLAI)		
	EI	FE	STM-1	EI	FE	STM-1
THAKOT	--	--	--	40	1	1
BANNA (ALLAI)	40	1	1	--	--	--
Total	40	1	1	40	1	1

16. Traffic Matrix For Thakot – Daur Miran – Judba Fiber Optic Link

NAME OF STATION	THAKOT		DAUR MIRAN		JUDBA	
	E-Is	FE	E-Is	FE	E-Is	FE
THAKOT	--	--	20	1	30	1
DAUR MIRAN	20	1	--	--	20	--
JUDBA	30	1	20	--	--	--
Total	50	2	40	1	50	1

17. Traffic Matrix For Pattan -- Palas Fiber Optic Link

NAME OF STATION	PATTAN			PALAS		
	EI	FE	STM-1	EI	FE	STM-1
PATTAN	--	--	--	40	1	1
PALAS	40	1	1	--	--	--
Total	40	1	1	40	1	1

### 18. Traffic Matrix For Pattan – Daasu Fiber Optic Link

NAME OF STATION	PATTAN			DAASU		
	E1	FE	STM-1	E1	FE	STM-1
PATTAN	--	--	--	40	1	1
DAASU	40	1	1	-	-	-
Total	40	1	1	40	1	1

#### 2. Service Availability

- (a) The bandwidth capacities shall become available in the relevant Tehsil Headquarter of the USF Areas in accordance with the USF Project Implementation Milestones identified in Schedule D and the requirements of this Schedule B.
- (b) The Service Provider shall ensure that the interfaces (bandwidth capacities) are maintained and continued, and meet applicable service standards and quality of service requirements, throughout the term of the SSA.
- (c) The availability of the bandwidth capacities shall be effectively advertised to other telecom operators in the relevant USF Areas, and the USF Service Provider shall publish its service plans and tariffs.
- (d) Retail or wholesale contracts for the bandwidth capacities shall be of a standard form and, if required, approved by the PTA.

To be provided to Registered Bidders Only.

## SCHEDULE D

### USF Project Implementation and Subsidy Payment Schedule

1. The USF Subsidy shall consist of a total subsidy payment of Pakistan rupees *[insert total amount of USF Subsidy]*, payable by USFCo to the USF Service Provider in specific installments in accordance with this Schedule D. All USF Subsidy installment payments shall be payable in Pakistan Rupees (PKR).
  
2. Subject to the provisions of Article Thirteen of the Agreement and this Schedule D, the USF Subsidy shall be payable in accordance with following schedule of payments. The payments shall include an initial mobilization payment and the Project Implementation Milestones and amounts identified in the following tables:

<b>Project Mobilization Payment</b>		<b>Installment Payable</b>  (percentage of USF Subsidy)	<b>Total Amount to be Paid</b>
1.	Payable within fifteen (15) Business Days of Effective Date.	20%	PKR [xxx]

<b>Milestone Number</b>	<b>Project Implementation Milestone</b>	<b>Installment Payable</b>  (percentage of USF Subsidy)	<b>Total Amount to be Paid</b>
1.	Demonstration that the USF Fiber Optic Network and USF FOC Services are available to, at least 25% of the total unserved Tehsil Headquarters & Towns identified in Schedule C and demonstration that at least 25% of FOC has been laid	20 %	PKR [xxx]
2.	Demonstration that the USF Fiber Optic Network and USF FOC Services are available to, at least 50% of the total unserved Tehsil Headquarters & Towns identified in Schedule C and demonstration that at least 50% of FOC has been laid	20 %	PKR [xxx]
3.	Demonstration that the USF Fiber Optic Network and USF FOC Services are available to, at least 75% of the total unserved Tehsil Headquarters & Towns identified in Schedule C and demonstration that at least 75% of FOC has been laid	20 %	PKR [xxx]

4.	Demonstration that the USF Fiber Optic Network and USF FOC Services are available to, at least 100% of the total unserved Tehsil Headquarters & Towns identified in Schedule C and demonstration that at least 100% of FOC has been laid	20 %	PKR [xxx]
----	--	------	-----------

3. Timing of completion of each of the Project Implementation Milestones set out in the table above shall be at the discretion of the USF Service Provider. However, the USF Service Provider must achieve First Project Implementation Milestone within nine (09) months and all four (04) Project Implementation Milestones within sixteen (16) months of the Effective Date (the “Final Implementation Date”).
4. For the purposes of the Project Implementation Milestones set out in the table above, “available” means that the USF FOC Services are fully operational and are available for commercial use in each of the identified Tehsil Headquarters and towns in accordance with the SSA, including, but not limited to, the service requirements and quality of service standards identified in Schedules A and B.
5. The USF Service Provider shall provide each of USFCo and the Technical Auditor with a notice in writing (a “Project Implementation Milestone Notice”) upon completion of each Project Implementation Milestone.
6. Within 45 Business Days of receipt of a Project Implementation Milestone Notice, the Technical Auditor shall either:
  - (a) certify in writing (a “Project Implementation Milestone Certification”) to the Parties that the Project Implementation Milestone has been completed; or
  - (b) Indicate in writing to the Parties that the Project Implementation Milestone has not been completed, providing reasons for this conclusion.
7. Where the USF Service Provider disputes any notice from the Technical Auditor that a Project Implementation Milestone has not been completed, the dispute will be resolved in accordance with Article 10 of the Agreement.
8. Each installment of the USF Subsidy will be paid to the USF Service Provider within 30 Business Days of USFCo receiving a written Project Implementation Milestone Certification from the Technical Auditor certifying that the USF Service Provider has completed the relevant Project Implementation Milestone.
9. The USF Subsidy installments shall be paid by a form of bank instrument selected by USFCo in its sole discretion, but all payments by USFCo to the USF Service Provider shall comply with all applicable laws, rules and regulations.
10. The USF Service Provider shall send USFCo a written confirmation of receipt of all USF Subsidy installments.

## **SCHEDULE E**

### **Material Events of Default**

#### **1. Breach by USF Service Provider**

- (a) Each of the following shall be deemed to be a material breach by the USF Service Provider for which USFCo will be entitled to terminate this Agreement in accordance with Article Fifteen:
  - (i) Failure by USF Service Provider to meet the Final Implementation Date identified in paragraph 3 of Schedule D.
  - (ii) The accumulation of liquidated damages under clause 4.01 (a) (iii) equal to ten percent (10%) of the USF Subsidy amount payable for the affected Project Implementation Milestone(s);
  - (iii) Repeated failure to meet the USF Service Availability and Quality Specifications set out in Schedules A and B, the cumulative effect of which significantly affects public use or enjoyment of the USF Services in the USF Areas.
  - (iv) The occurrence of a change in ownership or Control of the USF Network that is contrary to Article Three.
  - (v) Failure by the USF Service Provider to maintain its incorporation in and under the Companies Ordinance or to comply with eligibility requirements for Pakistani companies that are established under applicable Pakistani laws.
  - (vi) Any misconduct of the USF Service Provider, or any other Person on the USF Service Provider's behalf, described in section 52 of the RFA.
  - (vii) Failure of the USF Service Provider to adequately address any matters identified by an applicable regulatory authority falling within the scope of the USF Services, to such regulatory authority's reasonable satisfaction.
  - (viii) The USF Service Provider commits any other material breach of this Agreement which breach is not capable of being cured.

#### **2. Breach by USFCo**

- (a) It shall be deemed to be a material breach by USFCo for which the USF Service Provider will be entitled to terminate this Agreement in accordance with Article Fifteen, where:



- (i) The Technical Auditor fails to take any action in response to a Project Implementation Milestone Notice (reference: paragraphs 5 and 6 of Schedule D); or
- (ii) USFCo fails to pay undisputed payments of the USF Subsidy due to the USF Service Provider exceeding PKR 1,000,000.

**SCHEDULE F****Irrevocable Bank Guarantee**

**Issuing Bank:** \_\_\_\_\_  
(insert name and address of issuing bank)

**Date of Issue:** \_\_\_\_\_

**Bank Guarantee No:** \_\_\_\_\_

**Maximum Amount of Bank Guarantee** \_\_\_\_\_ (40% of subsidy amount)  
(insert amount, in PKR, in numbers and words)

**Applicant:** \_\_\_\_\_  
(insert full legal name and address of the USF Service Provider)

**Beneficiary:**  
**Universal Service Fund**  
**5<sup>th</sup> Floor, Habib Bank Tower**  
**Jinnah Avenue**  
**Islamabad**

On behalf of our client (the “Applicant”) we hereby issue in your favour this Irrevocable Bank Guarantee (the “IBG”) for the maximum amount identified above.

The IBG is available with the Bank, and will be paid, against presentation of the following documents:

- 1) The Beneficiary’s demand on the Bank in the form attached hereto as Appendix “A”, signed by the CEO of the Beneficiary, indicating the amount to be drawn under this IBG, the number of this IBG, the date of issue of this IBG, and the name of our Bank.
- 2) This IBG for endorsement by us of the amount drawn and, on final drawing, for cancellation.

This IBG is irrevocable and shall remain valid for 5 years up to and including the [*date*] day of [*month*], [*year*]

Partial drawings are permitted.

We will honour each drawing made in conformity with the terms of this IBG without enquiring whether you have, as between you and the Applicant, the right to make such drawing and without recognizing any claim of the Applicant.

This IBG shall be governed by and construed in accordance with the laws of Pakistan. We hereby irrevocably and unconditionally accept exclusive jurisdiction of the Courts at Islamabad.

---

Issuing Bank

---

Authorized Signing Officer

**SCHEDULE F(1)****Irrevocable Bank Guarantee**

**Issuing Bank:** \_\_\_\_\_  
(insert name and address of issuing bank)

**Date of Issue:** \_\_\_\_\_

**Bank Guarantee No:** \_\_\_\_\_

**Maximum Amount of Bank Guarantee** \_\_\_\_\_ (40% of subsidy amount)  
(insert amount, in PKR, in numbers and words)

**Applicant:** \_\_\_\_\_  
(insert full legal name and address of the USF Service Provider)

**Beneficiary:**  
**Universal Service Fund**  
**5<sup>th</sup> Floor, Habib Bank Tower**  
**Jinnah Avenue**  
**Islamabad**

On behalf of our client (the “Applicant”) we hereby issue in your favour this Irrevocable Bank Guarantee (the “IBG”) for the maximum amount identified above.

The IBG is available with the Bank, and will be paid, against presentation of the following documents:

- 3) The Beneficiary’s demand on the Bank in the form attached hereto as Appendix “A”, signed by the CEO of the Beneficiary, indicating the amount to be drawn under this IBG, the number of this IBG, the date of issue of this IBG, and the name of our Bank.
- 4) This IBG for endorsement by us of the amount drawn and, on final drawing, for cancellation.

1. This IBG is irrevocable and shall remain valid for 1 year up to and including the [date] day of [month], [year]

Partial drawings are permitted.

We will honour each drawing made in conformity with the terms of this IBG without enquiring whether you have, as between you and the Applicant, the right to make such drawing and without recognizing any claim of the Applicant.

This IBG shall be governed by and construed in accordance with the laws of Pakistan. We hereby irrevocably and unconditionally accept exclusive jurisdiction of the Courts at Islamabad.

---

Issuing Bank

---

Authorized Signing Officer

**Appendix “A”**

**To Irrevocable Bank Guarantee No. \_\_\_\_\_**

**Issued by \_\_\_\_\_ Bank**

**Drawn Under IBG No.: (*insert IBG number and date*)**

**To: (*insert came and address of Issuing Bank*)**

The undersigned hereby demands that (Name of Issuing Bank) pay to the order of the undersigned the sum of Pakistan rupees \_\_\_\_\_ under the IBG described above.

Dated: (*insert date*)

Universal Service Fund

\_\_\_\_\_  
CEO

## Schedule G – Letter of Lien

....., 20XX

Universal Service Fund  
 Fifth Floor, HBL Tower,  
 Jinnah Avenue, Islamabad

Sub:

LETTER OF LIEN TO THE EXTENT OF \_\_\_\_\_ [★<sup>1</sup>]

Dear Sirs,

In consideration of you, Universal Service Fund, a company listed under the Companies Ordinance 1984 having its principal office at Fifth Floor, HBL Tower, Jinnah Avenue, Islamabad through its Chief Executive Officer, (hereinafter referred to as “USFCo”), providing/agreeing to provide subsidy to the tune of Rs. \_\_\_\_\_ to us under USF Services and Subsidy Agreement (SSA) dated \_\_\_\_\_, and as per Clause 6.02 of the SSA and Rule 26(6) of USF Rules 2006, we, \_\_\_\_\_ Limited, a company incorporated under the Companies Ordinance 1984 and having its registered office at \_\_\_\_\_ (hereinafter referred to as the “USF Service Provider”), do hereby create Lien on the assets specified in Schedule-A hereto (the “Property under Lien”) in your favour for the purpose of securing the provision of services in the USF area for a period of ten years from the Effective Date of SSA or repayment of the Subsidy Amount upto an amount of Rs. [★<sup>2</sup>] (Rupees \_\_\_\_\_ Only) and other moneys payable under the SSA.

We further, irrevocably and unconditionally, undertake, agree, covenant and confirm as follows:

### **ARTICLE ONE - LIEN**

#### **1.01 Property under Lien**

We hereby create lien in favour of USFCo all our moveable and immovable properties mentioned in Schedule A to this Letter and our assets as may hereafter be acquired by us for deployment of the USF Network in the USF Areas, together with the benefits of all rights relating thereto (all such properties and assets herein to be collectively called the “Property under Lien”) as security for provision of the USF Services in the USF Areas in accordance with the SSA, or repayment by us of the USF Subsidy and other moneys payable under the SSA.

#### **1.02 No further lien**

The Property under Lien shall be kept and held always distinguishable and as USFCo’s exclusive property specially appropriated to the security and we shall not create any mortgage, charges, lien or encumbrance affecting the same or part with the Property under Lien except with the prior permission in writing of USFCo.

#### **1.03 Right to inspect**

We hereby permit USFCo, its agents, nominees and employees from time to time after giving reasonable notice to enter upon, during normal working hours, any premises wherein the Property under Lien or any part thereof may for the time being be and to view/inspect and value the same and take inventories thereof and shall render to USFCo, its agents, nominees and employees all facilities and reasonable assistance as may be required for any of the purposes aforesaid.

<sup>1</sup> Insert Value of USF Subsidy as mentioned in SSA.

<sup>2</sup> Insert Value of USF Subsidy as mentioned in SSA.

**1.04 Free from distress**

We shall punctually pay all rents, rates, taxes and other outgoing expenditures for the premises wherein the Property under Lien shall be stored and keep the same free from distress.

**1.05 Insurance**

During the validity of the SSA, we shall keep the Property under Lien insured in accordance with Article 7 of the SSA.

**1.06 No change**

We undertake that during the term of the SSA the listed machinery and equipment (as further defined in the USF Services and Subsidy Agreement) shall not be removed, disposed of or impaired in any manner whatsoever, except for repair, maintenance or replacement in the ordinary course of business.

**1.07 Information**

The USF Service Provider shall make and furnish to USFCo all statements and reports of the cost and market value of the Property under Lien and a full description thereof and produce such evidence in support thereof as USFCo may from time to time reasonably require.

**ARTICLE TWO - REPRESENTATION AND INDEMNIFICATION****2.01 Right to enter**

In the event of, we committing a breach of any of the terms and conditions of this letter or of the SSA, USFCo and its officers and agents shall be entitled without notice to us and at our risk and expense and if so required as attorneys for and in our name to enter and remain at any place where the Property under Lien shall be and to take possession or recover and receive the same and/or appoint any officer or officers of USFCo as receiver or receivers of the Property under Lien, confiscate the same, and/or sell by public auction or private contract or otherwise dispose off or deal with all or any part of the Property under Lien and to enforce, release, settle, compromise and deal with any of aforesaid without being bound to exercise any of these powers or being liable for any loss in the exercise thereof, except where such loss is caused by the negligence or misconduct of USFCo or its officers, agents or receivers and without prejudice of USFCo's other rights and remedies including the right of legal action against us and to apply the net proceeds of such sale in or towards the repayment of the USF Subsidy and any other moneys that have become due under the SSA and have not been paid by us and we hereby agree to accept USFCo's account of sales and realization, except in case of any error or omission, and to pay any shortfall or deficiency therein shown. Provided, however, that the powers hereunder shall always be exercised to the extent of the Property under Lien.

**2.02 Clear Title**

We hereby declares that all the Property under Lien is our absolute property, at our sole disposal and free from any prior charges or encumbrance and that we have not done or knowingly suffered or been party or privy to anything whereby we are in any way prevented from creating lien over Property under Lien in the manner aforesaid. We shall do and execute at our cost all such acts and things for further and more particularly ensuring that the rights and remedies regarding the Property under Lien or any part thereof, under this letter, remain fully enforceable for the benefit of USFCo, as may be required by USFCo, and for giving better effect to this letter, we authorize and irrevocably appoint USFCo and/or its officers as attorney or attorneys for and in our name to act on our behalf and to execute or do any acts or things which we ought to execute or do under this letter and generally to use our name in the exercise of the powers hereby conferred.



**2.03 Indemnification**

- a) We hereby agree and undertake to comply with all provisions of the various laws, orders, regulations, rules and notifications, already promulgated or that may be promulgated hereafter by the Government or any other authority.
- b) Nothing herein contained shall prejudice any of USFCo’s rights or remedies in respect of any present or future security, guarantee, obligation or decree for our any indebtedness or liability.
- c) We shall indemnify and keep USFCo safe, harmless and indemnified against all losses, damages, detriments, harms, claims, liabilities, demands, actions, proceedings, costs, charges and expenses that may reasonably be sustained by or be made against or incurred by USFCo or to which USFCo may become a party hereunder, provided the same have arisen solely and directly from and default or breach of our obligations under the SSA and this Letter.

**2.04 Continued security**

The security hereunder shall operate as continuing security for all our liabilities notwithstanding any partial performance that may be made from time to time and continue till we shall discharge our obligations under this letter and the SSA in accordance with their respective terms, whereupon this security shall stand discharged.

**ARTICLE THREE - GENERAL**

**3.01 Remedies**

Nothing herein contained shall extinguish, derogate from, curtail, prejudice, impair or otherwise affect all or any of USFCo’s rights and remedies under the said SSA or that may otherwise be available to USFCo under any law in respect of the USF Subsidy or the SSA.

**3.02 No Waiver**

If USFCo does not enforce any of its rights hereunder in the event of breach or non-compliance by us with the terms and conditions herein contained, the inaction or omission of USFCo to take action shall not be treated as waiver or abandonment of any such rights.

**3.03 Territorial Jurisdiction**

This Letter shall be governed by and construed in accordance with the laws of Pakistan and the Courts at Islamabad shall have exclusive jurisdiction in all matters under this letter.

USF SERVICE PROVIDER

Per: \_\_\_\_\_  
[insert name and title]

SIGNED, SEALED AND DELIVERED )  
in the presence of: )

\_\_\_\_\_) )

Witness (1) ) \_\_\_\_\_  
[insert name]

\_\_\_\_\_) )

Witness (2) ) \_\_\_\_\_  
[insert name]

**SCHEDULE “A”**

(As per list attached and updated from time to time).

USF SERVICE PROVIDER

Per: \_\_\_\_\_  
[insert name and title]

SIGNED, SEALED AND DELIVERED )  
in the presence of: )

\_\_\_\_\_) )  
Witness (1) )

\_\_\_\_\_) )  
[insert name]

\_\_\_\_\_) )  
Witness (2) )

\_\_\_\_\_) )  
[insert name]

### **Annex 7: Dispute Resolution Terms and Processes**

(1) USFCo and Applicant shall make every effort to resolve amicably by direct informal negotiation any disagreement or dispute arising between them under or in connection with participation in the RFA Process.

(2) Neither party to the disagreement or dispute shall commence any appeal, action or arbitration proceedings for at least, twenty-eight (28) days after any unresolved disagreement or dispute has been notified to the Chief Executive Officer of USFCo and a similarly senior officer of the Applicant. These senior officers shall engage in further discussions in an effort to resolve the disagreement or dispute within the 28 day period.

(3) If the parties have failed to resolve their disagreement or dispute using the processes described in paragraphs (1) and (2), then either party may give notice to the other party of its intention to commence appeal, action or arbitration in accordance with the laws of Pakistan and applicable procedures.

### Annex 8: Tentative Time Schedule & Correspondence Contact

1. The timetable for the RFA events, beginning with publication of the pre-auction notice, is set out below.

<b>Tentative Time Schedule (Khyber Pakhtunkhwa Package)</b>	
<b>Event</b>	<b>Calendar Date</b>
Publication of Specific Procurement notice	April 19, 2013
Distribution of RFA document	April 19, 2013
Deadline for submission of questions by bidders	May 07, 2013
Answers to questions	May 14, 2013
Deadline for Registration of bidders	May 20, 2013
<b>Deadline for submission of Proposals</b>	<b>May 30, 2013</b>
Opening of the Qualifications & Service Proposal	May 30, 2013
Complete evaluation of Qualifications & Service Proposals and announcement of Qualified Applicants	June 20, 2013
Opening of USF Subsidy Proposal of Qualified Applicants	June 24, 2013
Financial Evaluation & Issue of LOI to the Qualified Applicant with lowest subsidy offer	July 01, 2013
Receipt of Performance Bond	July 15, 2013
Execution of USF Services and Subsidy Agreement and related transaction documents	July 22, 2013

2. The sealed Proposal package shall be delivered to USFCo at the address specified in clause 4 of this Annex no later than **1500 hrs on Thursday 30<sup>th</sup> May 2013**.
3. If the scheduled day of an event falls on a gazetted holiday in Pakistan, the day of the event will be the next working day following the holiday.
4. All correspondence shall be addressed to:

**GM Projects & Technology, USFCo.**  
 Fifth Floor, HBL Tower,  
 Jinnah Avenue, Blue Area  
 Islamabad, Pakistan

Telephone: 051-9212308 & 9212309  
 Fax: 051-9214261  
 e-mail: [projects.tenders@usf.org.pk](mailto:projects.tenders@usf.org.pk)